

micro **Hydraulics**

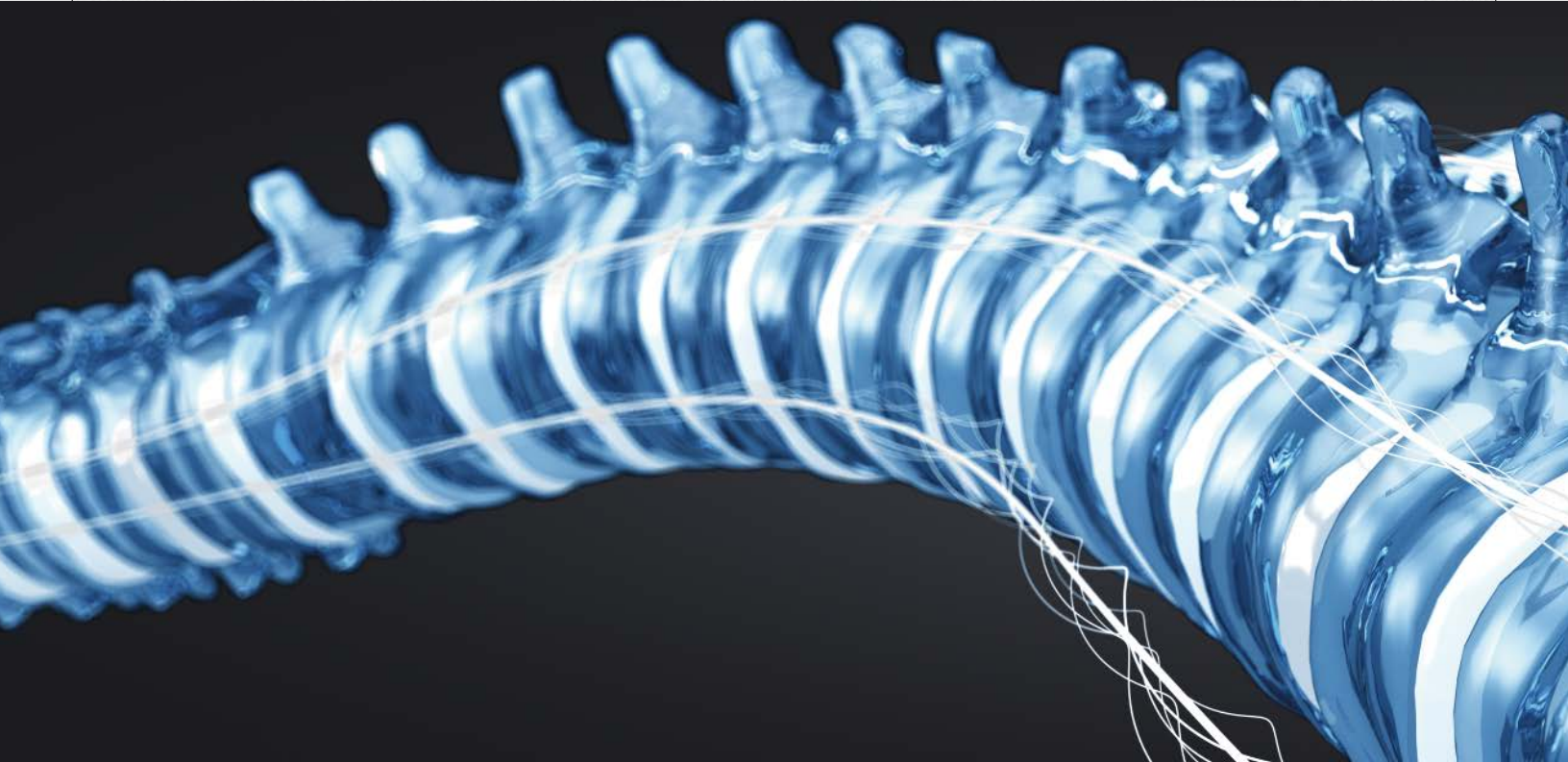

ERGOSWISS
hydraulic and spindle lift systems

The Challenge



Ergonomics

Physical discomforts such as backache and leg pains have a major impact on a person's quality of life and therefore a company's performance. These ailments can lead to a decline in productivity, a deterioration of work quality, and a rise in sick leave.

The aim of ergonomics is to adapt the working environment to better meet people's needs. Specifically, this means adapting the height at which people work to their different body heights and activities, as well as optimizing working conditions, work processes and equipment.

Perfectly adjusted work stations optimize the material supply flow and improve the work process.

Ergonomic work stations promote employee motivation, thereby increasing productivity. Taking these factors into consideration, you can see how the Ergoswiss system can pay for itself in just a few months.

About us

We have been developing and manufacturing hydraulic and spindle lifting systems since 1999. The lifting systems are available as lifting columns and in the form of table legs and table bases. They are used for height-adjustable work stations or for a wide range of other applications. We strive for quality, progress and reliability.

Our products aim to improve the working environment and enhance your comfort at work.

We supply:

- manufacturers of operating, assembly and laboratory work stations
- manufacturers of machines and conveyer systems
- manufacturers of industrial kitchens and healthcare institutions
- manufacturers from the furniture and office furniture industries

The Solution



Service

In the field of mechanical engineering, our products offer a cost-efficient and simple alternative to conventional drive systems.

We offer:

- expert advice
- online configuration with automatic creation of a quotation
- rapid response to requests for quotations
- short lead times
- faultless after-sales service
- world-wide presence and delivery

We would be happy to help meet your individual needs. Visit our website or simply give us a call.

Ergoswiss America Inc.
111 W. Jackson | 60604 Chicago | Illinois USA

Phone: +1 312 675 6090

info@ergoswiss.us
www.ergoswiss.us

Technical modifications reserved

System configurator

Assemble your very own lifting system at **www.ergoswissconfig.com**.

Whether you need individual lifting elements or a complete base frame, all we need is a few clicks from you to configure a suitable product. You will then receive a personal quotation by e-mail.

System Structure

Modular und flexibel

The power unit (1) drives hydraulic oil out of the pump (2) and into up to ten cylinders*(3), which causes them to be extended. The principle of single-acting hydraulics requires a restoring force of at least 15 lbs (7kg)** per cylinder to press the hydraulic oil back into the pump.

The Ergoswiss system is assembled using flexible hoses (4). It works with any load and is fully synchronous. Thanks to its small dimensions, high load capacity and quiet operation, our system offers distinct advantages over conventional lifting systems.

* Linear units or table legs can be used instead of the cylinders.

** Restoring forces of up to 55 lbs (25kg) are required for long hoses, or if there is friction in the guide rail or a misalignment in assembly.

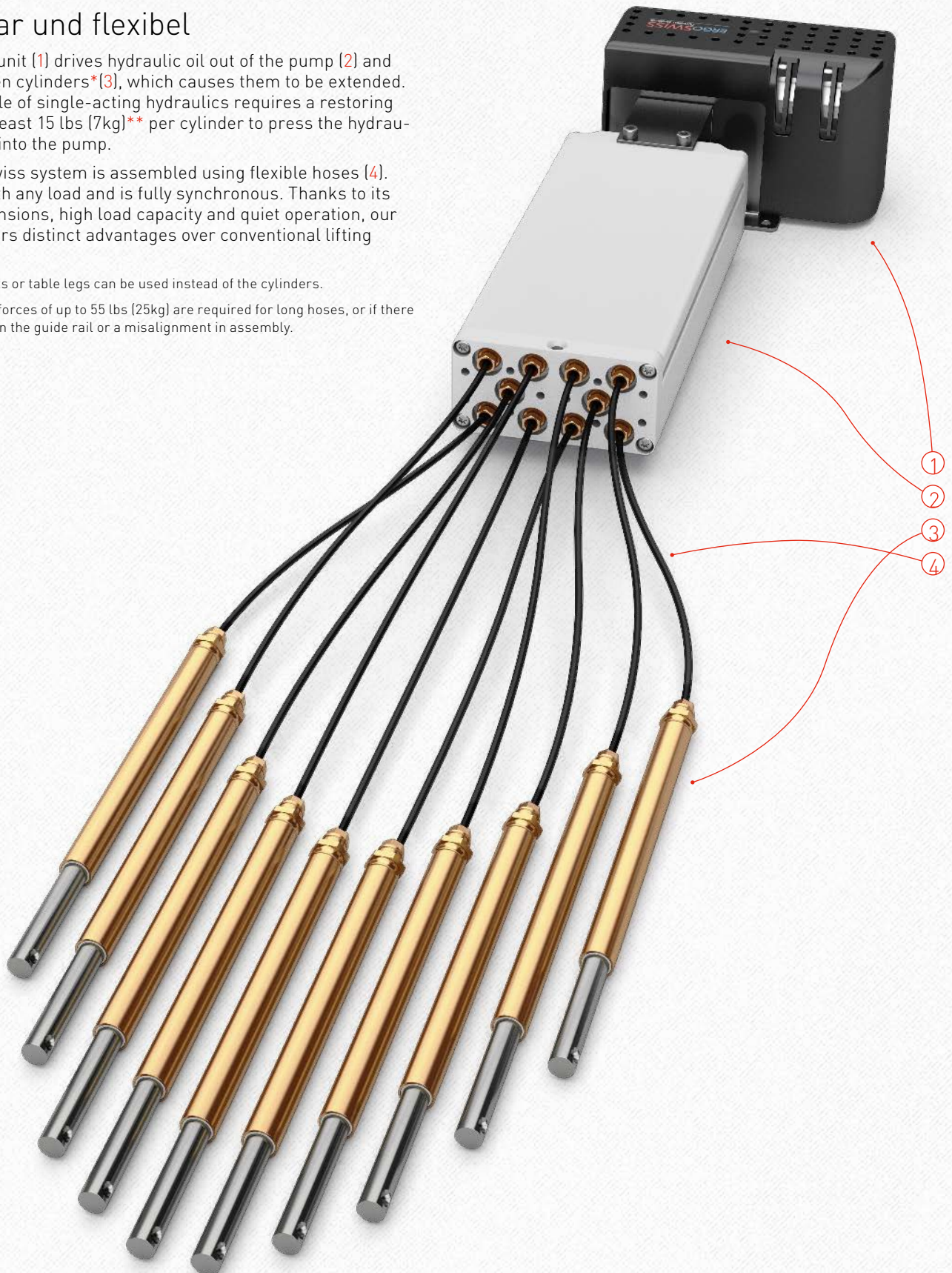

System Function

Simple and ingenious

Through the rotary motion of the power unit (1), the piston rods (2) are pushed by the pusher block (3) into the pressure elements (4). This then presses the hydraulic oil (5) out of the pressure elements and into the connected cylinders.

Each connected cylinder has its own pressure element in the pump.

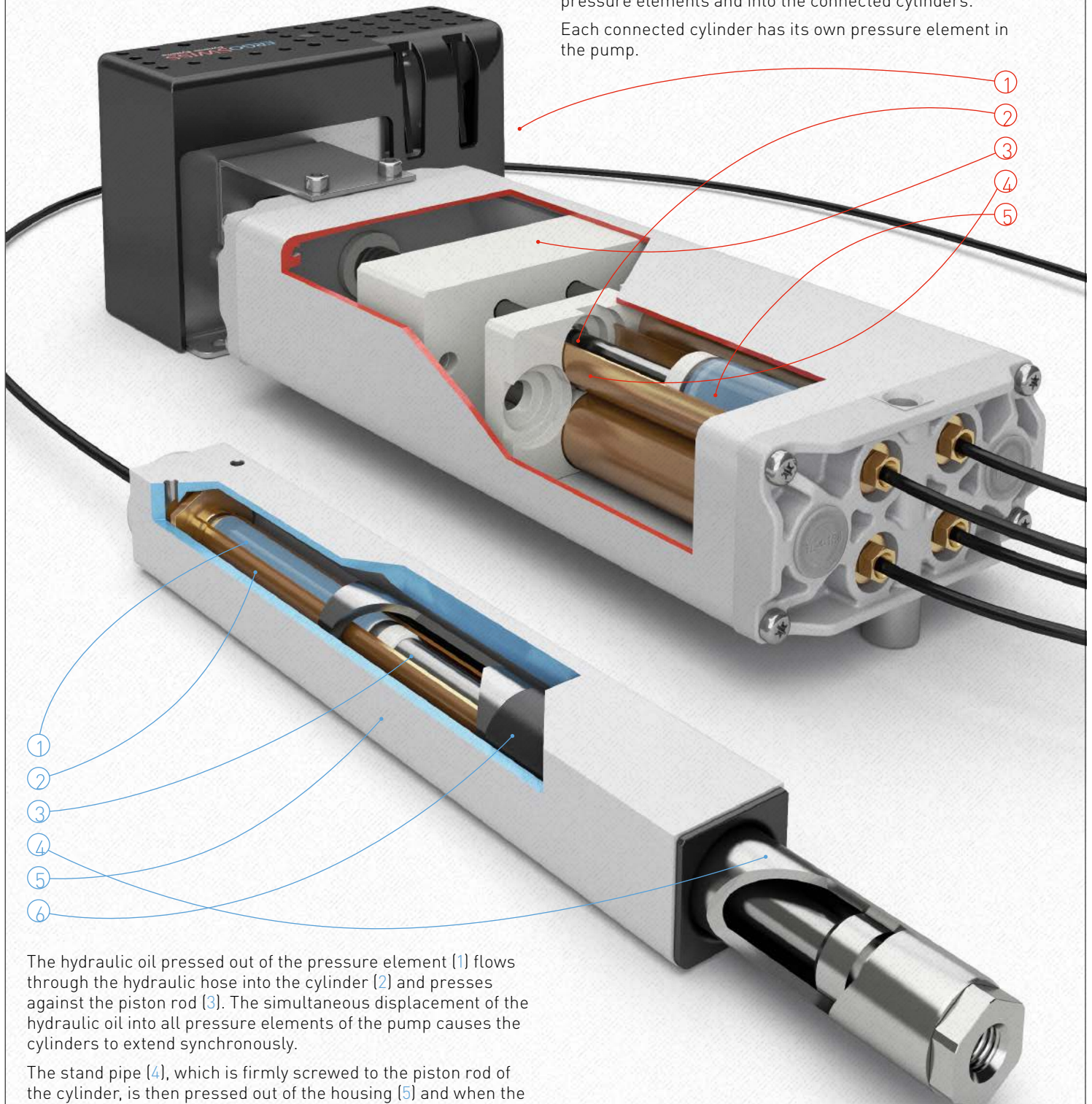







The hydraulic oil pressed out of the pressure element (1) flows through the hydraulic hose into the cylinder (2) and presses against the piston rod (3). The simultaneous displacement of the hydraulic oil into all pressure elements of the pump causes the cylinders to extend synchronously.

The stand pipe (4), which is firmly screwed to the piston rod of the cylinder, is then pressed out of the housing (5) and when the cylinder extends, it slides through the plastic bushing inside the aluminum housing (6).

Product Overview

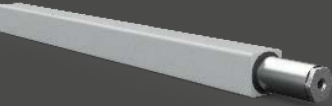
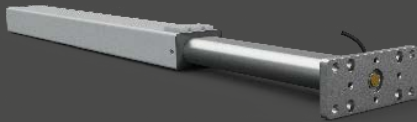
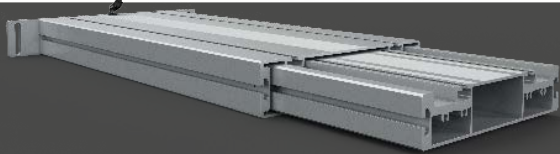
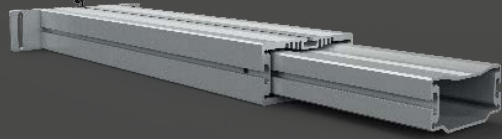
Some of the features of our hydraulic lifting systems:

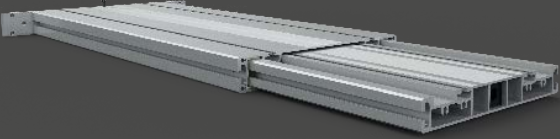
- Simple and flexible activation of several lifting elements.
- One pump allows the synchronous control of 1 to 10 lifting elements.
- The pumps are driven by an electric drive unit or a hand crank.

Lifting element	Stability	Cross section	Installation
	●●○○○	1.4" x 1.4" (35 x 35 mm)	10" – 34" (252 – 867 mm)
	●●○○○	1.4" x 1.4" (35 x 35 mm)	10" – 34" (252 – 867 mm)
	●●●○○	1.8" x 1.8" (45 x 45 mm)	18" – 27" (463 – 690 mm)
	●●●●●	3.1" x 2.0" (80 x 50 mm)	16" – 25" (414 – 640 mm)
	●●●●○	10.2" x 2.8" (260 x 60 mm)	21" / 25" (530 / 630 mm)
	●●●●○	5.9" x 2.8" (150 x 70 mm)	21" / 25" (530 / 630 mm)
	●●●○○	1.8" x 1.8" (150 x 70 mm)	20" / 39" (500 – 1000 mm)
	●●●●○	10.2" x 1.6" (260 x 40 mm)	21" / 25" (530 / 630 mm)
	●●●●●	2.0" x 2.0" (50 x 50 mm)	27" (683 mm)

- As our control units are connected in parallel, they can drive up to 40 lifting elements synchronously.
- The lifting system is completely silent in crank drive.
- The restoring force needs to be taken into account as it is a single-acting system.

Lifting distance system	Hydraulic lifting system	Max. load power per lifting element*	Spindle lifting system	Max. load power per lifting element*
6" – 28" (150 – 700 mm)	LA	330/550 lbs (150/250 kg)	SLA	330 lbs (150 kg)
6" – 28" (150 – 700 mm)	LD	330/550 lbs (150/250 kg)		
12" – 20" (300 – 500 mm)	LG	330/550 lbs (150/250 kg)	SLG	330 lbs (150 kg)
12" – 20" (300 – 500 mm)	TA	330/550 lbs (150/250 kg)		
12" / 16" (300/400 mm)	TL	330/550 lbs (150/250 kg)	SL	330/660 lbs (200/300 kg)
12" / 16" (300/400 mm)	TM	330/550 lbs (150/250 kg)	SM	330/660 lbs (200/300 kg)
12" / 16" (300/400 mm)	TQ	330/550 lbs (150/250 kg)	SQ	330 lbs (150 kg)
12" / 16" (300/400 mm)	TT	330/550 lbs (150/250 kg)		
16" – 20" (400 / 500 mm)	TU	330/550 lbs (150/250 kg)		

ergo Segments



Assembly Assembly benches, piping systems, packaging tables, desks, aluminum profile systems, workbenches, measuring tables, watchmaker benches, etc.



Care Couches, laboratory benches, flow cabinets, bathtubs, chemistry work stations, examination chairs, veterinary examination tables, etc.



Catering Industrial kitchens, dining tables, pay stations, buffets, steam extractors, food warmers, etc.

ergo Segments



Furniture Kitchens, cooking islands, dining tables, display cabinets, televisions, beds, tables for people with disabilities, tables for arts and crafts/hobbies, coffee tables, etc.



Industry Working platforms, conveyor systems, machine hoods, welding benches, tool-setting tables, runways, etc.



Office Student desks, lecterns, conference tables, PC and CAD stations, monitors, whiteboards and interactive screens, etc.

ergo Applications

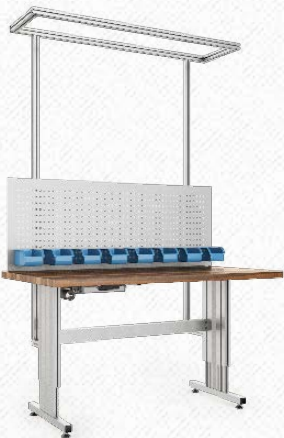
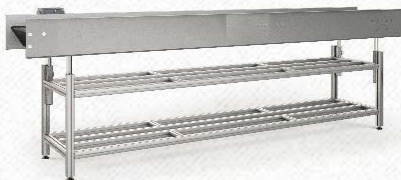

ergo Applications





Powerful and quiet

The pumps **PA**, **PB** and **PF** represent the heart of our height adjustment system.

The flexible connections, the minimal space requirements and the option of mounting the pumps in any location (even outside a system) mean that Ergoswiss systems can be integrated in very slim and complex objects.

Our pumps can activate up to 10 cylinders quietly, continuously and absolutely synchronously – even in the case of uneven loads – lifting weights up to 1760 lbs (800 kg).

The pumps are driven by an electric drive unit or a hand crank.

A restoring force of at least 15.4 lbs (70 N)* should be available per cylinder to push the hydraulic oil back into the pump during retraction (single-acting hydraulics).

The pumps and cylinders are connected with a hydraulic hose (Ø 0,16" / 4 mm). The maximum hose length is 26ft 3" (8 m), the minimum bending radius is about 1" (25 mm).

The pump housing is an extruded aluminum profile with a plain anodized finish.

Three fixing holes are available to mount the pumps. An additional mounting T-slot is provided on both sides for mounting the **PF** pump.

* Restoring forces of up to 55 lbs (25 kg) are required for long hoses, or if there is friction in the guide rail or a misalignment in assembly.

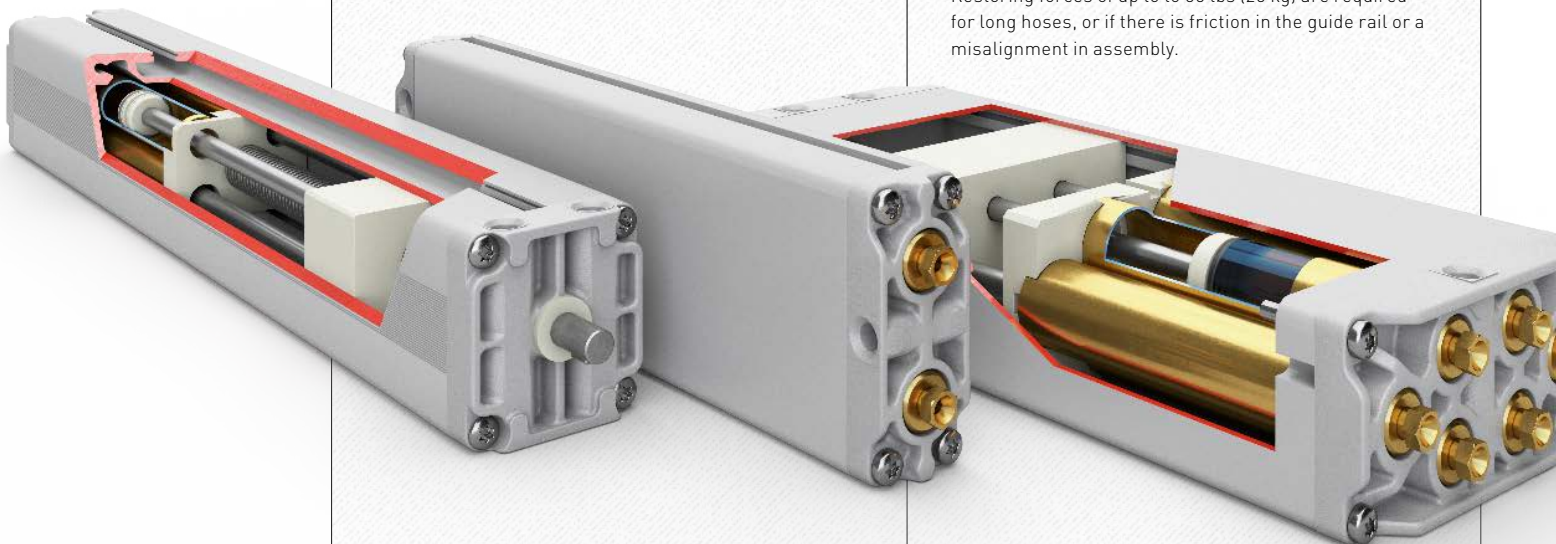

Type PA|PB|PF

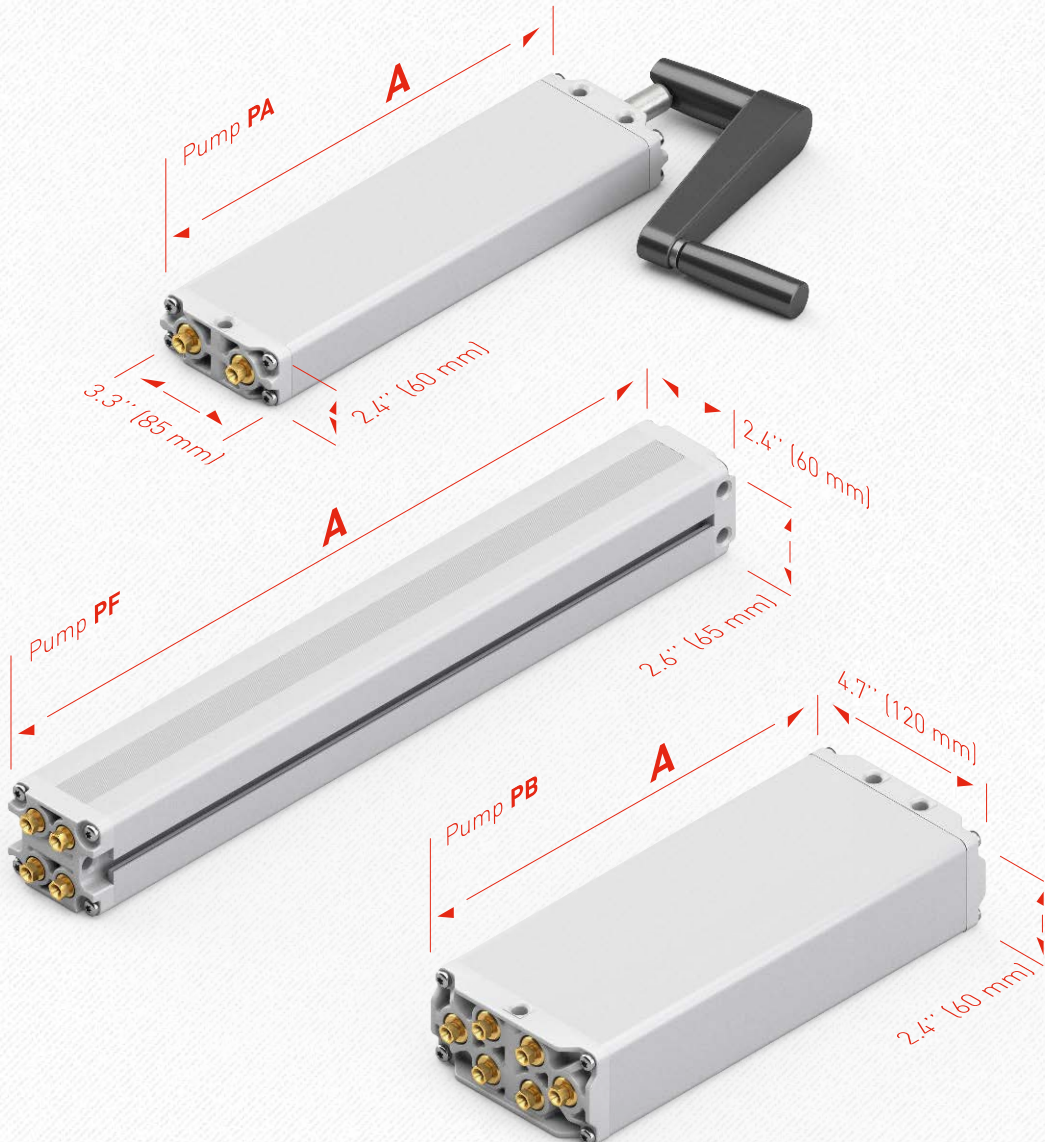

Detailed CAD drawings in various formats can be found at www.ergoswiss.us

Technical data

- Type **PA** to drive 1 or 2 cylinders and for a max. system power of 1100 lbs (500 kg)
- Type **PB** to drive from 3 to 10 cylinders and for a max. system power of 1760 lbs (800 kg)
- Type **PF** to drive from 3 to 4 cylinders and for a max. system power of 1760 lbs (800 kg)
- Maximum lifting speed of 0.4" (10 mm) per crank revolution, or max. 1.2"/s (30 mm/s) with electric drive
- Food-grade fluids can also be used
- Other models on request

Pump PA PB PF	
770 + 1320 lbs (350 + 600 kg)	A
x815	12" (298.5 mm)
x820	14" (358.5 mm)
x830	19" (480.5 mm)
x840	24" (600.5 mm)
x850	28" (722.5 mm)
x860	33" (842.5 mm)
x866	36" (923.5 mm)
x870	38" (969.5 mm)
1760 lbs (800 kg)	A
x418	19" (480.5 mm)
x430	28" (722.5 mm)
x440	36" (923.5 mm)



Simple and convenient

Our pumps can be operated with a hand crank or an electric drive unit. Your choice will depend on the desired level of convenience and on price considerations.

When folded in, the hand crank entirely disappears from view under the table.

The following options are available:

- detachable hand crank
- stainless steel hand crank
- torque limiter



The electric drive unit has an intelligent control system with space for 4 memory positions.

Height adjustment is achieved via cable remote control. It is mounted on the underside of the table and can be neatly pushed under the table top. The table height is displayed digitally on the remote control.

The power supply unit (230 VAC or 110 VAC) is integrated in the control unit. An electric current monitoring function protects the electric drive unit from overload and also serves to protect the system on start-up.

Delivery includes the motor, control unit with 3-pole power cable and cable remote control (6ft7" or 2 m cable length) with position memory.

The drive units are not suitable for continuous operation. After one minute of operation, the drive unit needs to rest for about 10 minutes (duty cycle 10%). The nominal travel decreases by about 0.6" (15 mm) with an electric drive unit.

The following accessories are available:

- various versions of manual switches (simple on/off switch, foot switch, infra-red remote control)
- control cable to use your own switches
- safety strips
- extension and split cables
- cable to synchronize max. 4 power units
- country-specific power cables (3-pole)

Type PXD

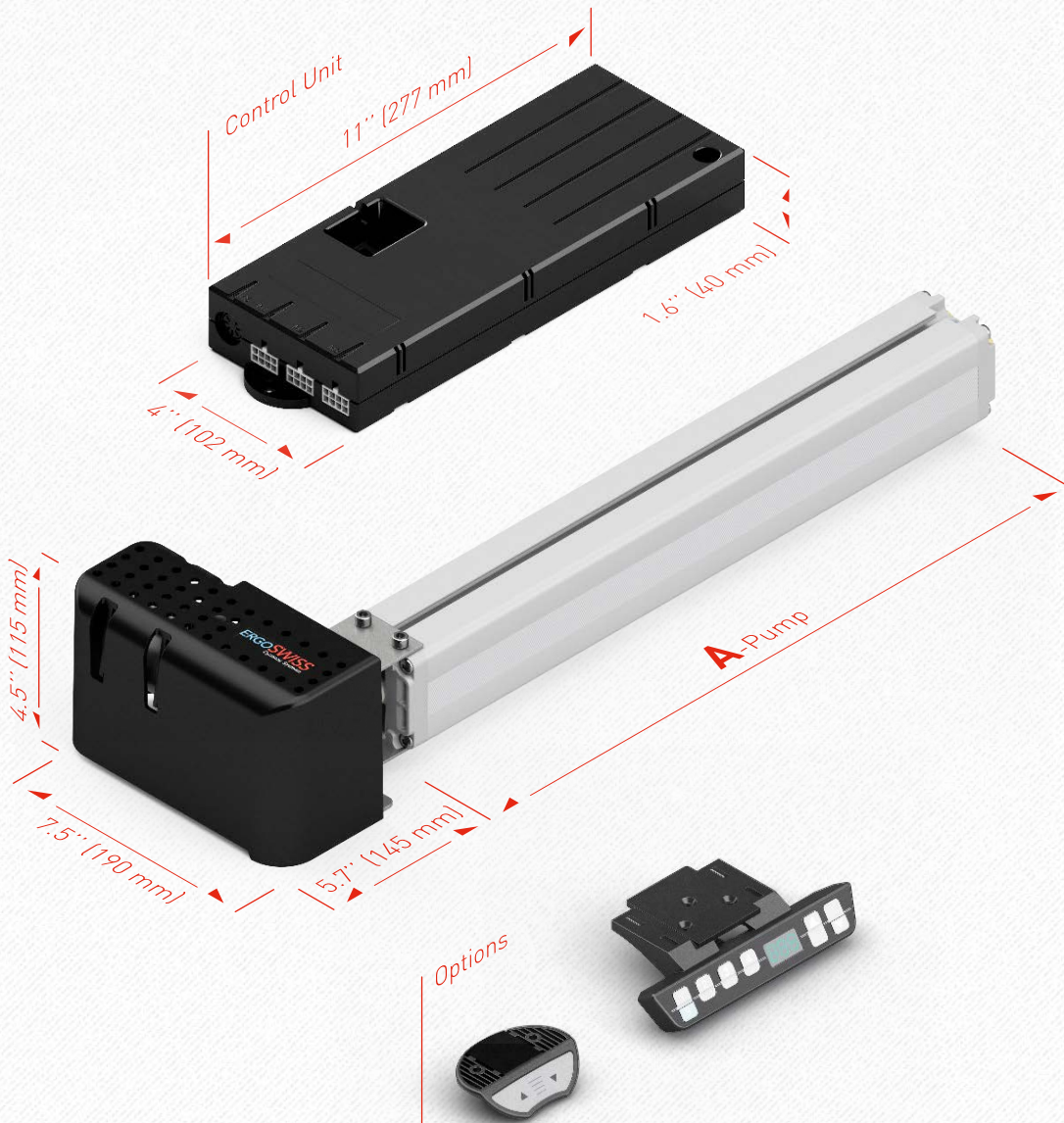

Technical data

- 4 memory positions
- Digital height display
- Mains voltage 230/110 VAC
- Motor voltage 24 VDC
- Power rating approx. 340 VA
- Standby output < 0.6 W
- Idle running speed 180 rpm
- Protection class IP 20
- Overload protection
- Thermal protection
- Duty cycle monitoring
- Other models on request

Detailed CAD drawings in various formats can be found at www.ergoswiss.us



Strong and slim

Our cylinders are ideal for quiet, quick and precise adjustments. Highly complex designs can be realized thanks to the simultaneous activation of up to ten cylinders.

The cylinders are designed to be integrated into existing guide rails and should only be exposed to minor lateral forces. They are used for height and tilt adjustments.

The cylinder is the basic element of all linear units and table legs and is therefore used in all our elements. It is made of brass tubing and has a piston rod made of stainless steel.

The clamping rings and screws (M8x1) are for connecting the hose to the pump and cylinders.

The flexible pressure hose has the following properties:

- exterior diameter: 0.16" (4 mm)
- minimum permissible bending radius is about 1" (25 mm)
- maximum operating pressure: 1450 psi (100 bar)

The following accessories are available:

- Y, L or straight-through fittings
- hose couplings
- hose blanking plugs
- brackets D6 and D8 to mount the cylinders
- hose rupture protection «V» (check valve)

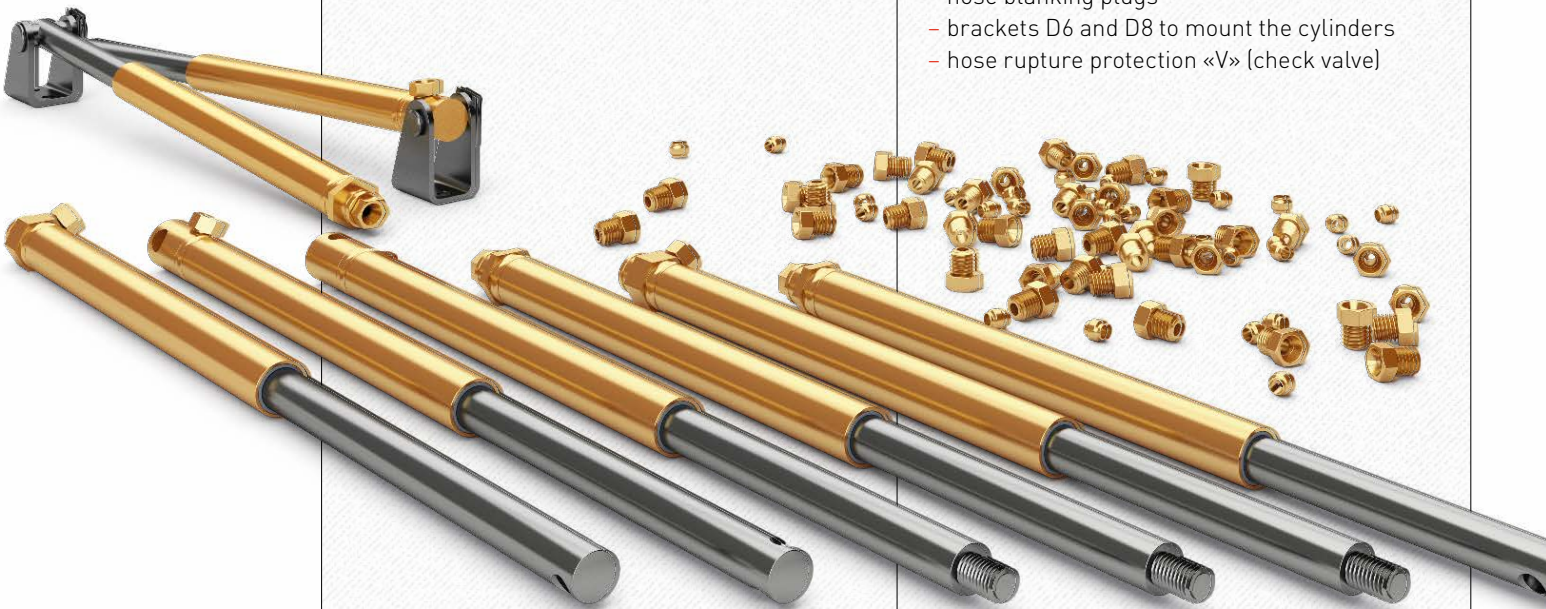

Type **CB|CD|CE|CH|CI**



Options



Technical data

- Max. load per cylinder:
330 lbs (150 kg) **CX 14**
550 lbs (250 kg) **CX 18**
- The system load depends on the pump
- Lift strokes up to 28"
(700 mm)
- The cylinders should not be exposed to tensile forces
- Minimum restoring force of 15 lbs (70 N) required
- The cylinders must be installed within an existing guide rail
- Food-grade fluids can also be used
- The cylinder is supplied with a 9ft 10" (3 m) hydraulic hose pre-assembled as standard

Cylinder CX		
	A with Ø0.6" (16)	A with Ø0.8" (20)
CB	2.2" (55 mm)	2.4" (62 mm)
CD	2.4" (61.5 mm)	2.7" (67.5 mm)
CE	2.2" (56.5 mm)	2.5" (62.5 mm)
CG	1.7" (44 mm)	2.0" (49 mm)
CH	2.0" (50 mm)	2.2" (57 mm)
CI	1.9" (49 mm)	2.1" (54 mm)

Standard lifting distance (mm):

$\text{Ø } 16$:
6" (150), 8" (200), 12" (300), 16" (400),
20" (500), 24" (600), 28" (700)

$\text{Ø } 20$:
6" (150), 8" (200), 12" (300), 16" (400)



Universal and compact

The linear unit consists of a cylinder and a linear guide rail and is a compact and robust lifting element. It can be installed directly onto or into existing objects. This means that a table or other devices can easily be equipped or retrofitted with a lifting system.

Four M5 screw threads are provided to mount the linear units **LA** and **LD**. Four M6 screw for **LG**.

The housing of the linear unit is a plain anodized aluminum profile. The stand pipe is made of stainless steel and positioned in a plastic bushing.

The linear unit is available in different versions:

- LA-R: radial tube outlet
- LA-F: with built-in restoring spring
- LA-RF: stainless steel version
- LA-ESD: ESD-compatible
- LA-V: with built-in hose rupture protection

The height is adjusted by means of a hydraulic pump operated by a hand crank or an electric drive unit.

The following accessories are available:

- mounting plates allowing other assembly options for the linear units
- adjustable feet made of rubber or aluminum to compensate for uneven flooring
- Castor incl. brake (load 150 lbs or 70 kg)

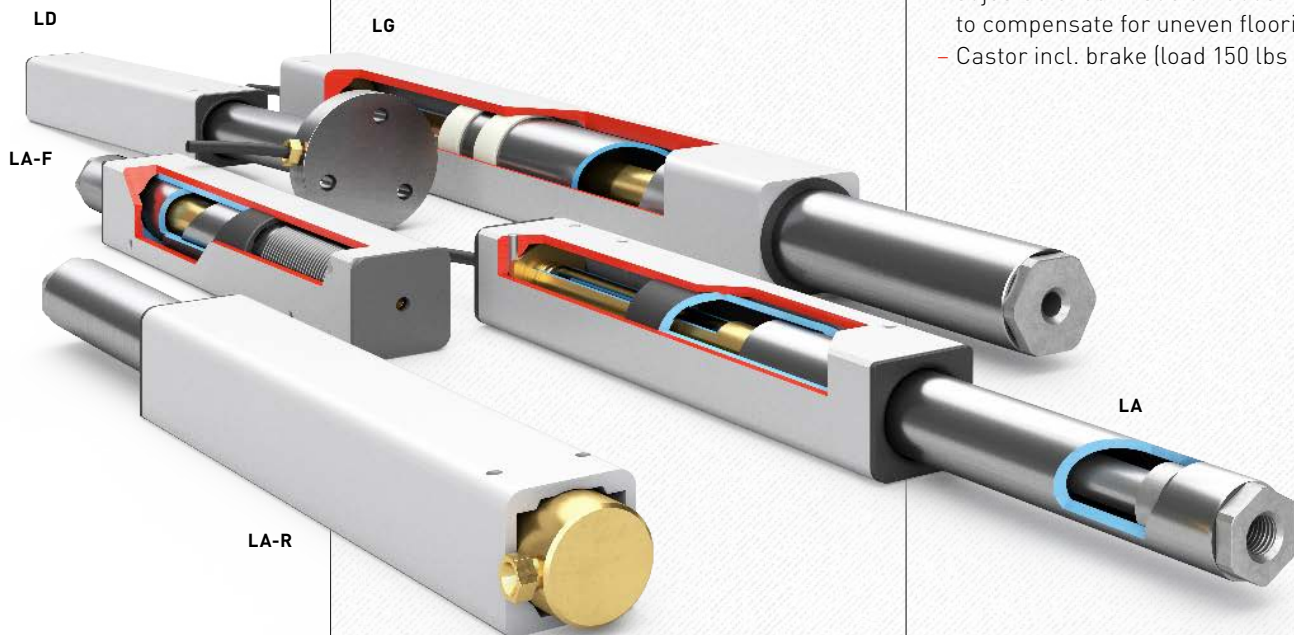

Dimensions of LA|LD|LG

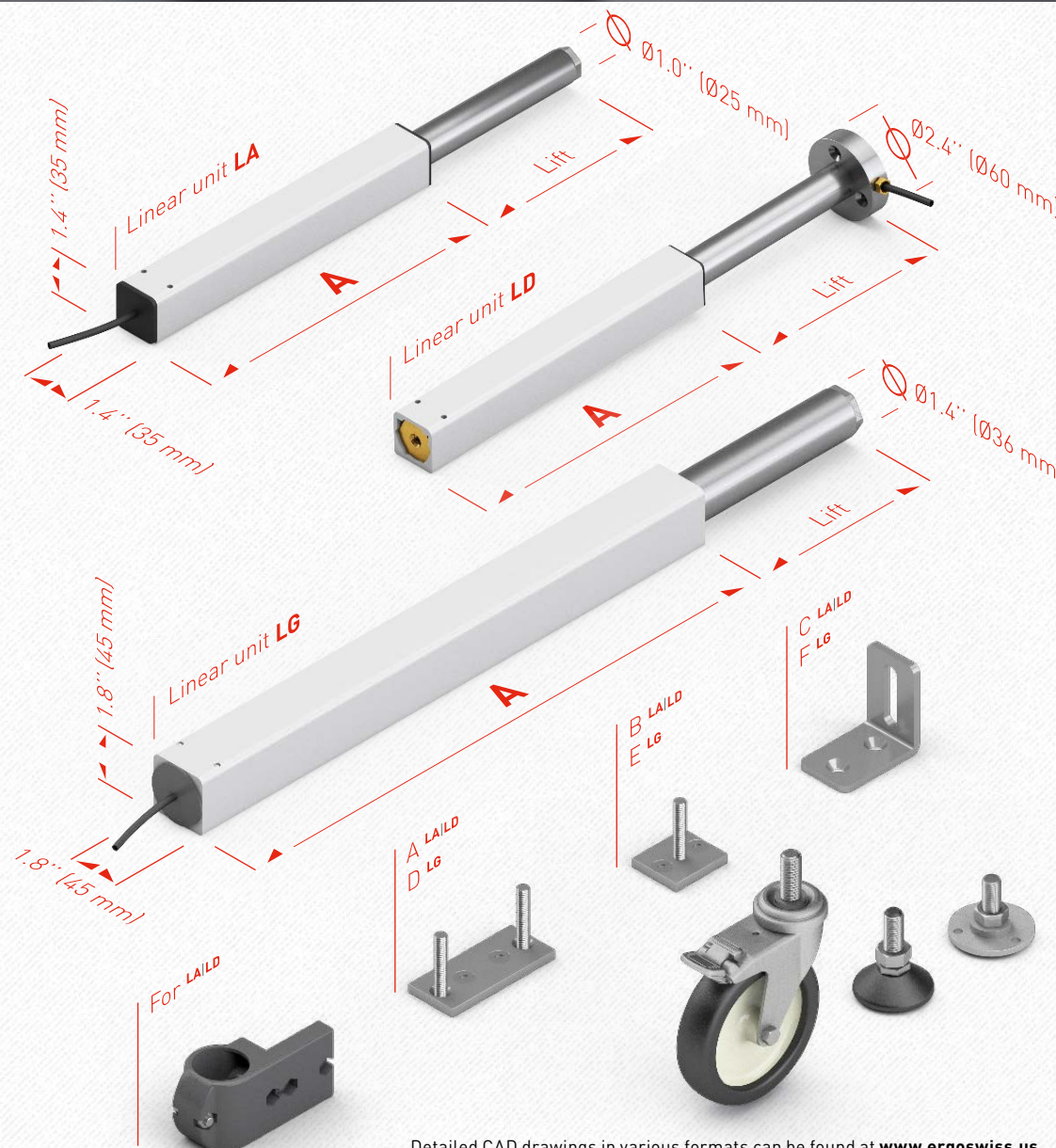

Technical data

- Versatile linear guide rail with slide bearings
- The system load depends on the pump
- Load per lifting element
330 lbs (150 kg) (LX 14)
550 lbs (250 kg) (LX 18)
- Lifting distance max. 28" (700 mm)
- Max. static bending moment $M_b = 110 \text{ lbf ft}$ (150 Nm)
- Max. dynamic bending moment $M_{b\text{dyn}} = 35 \text{ lbf ft}$ (50 Nm)
- Food-grade fluids can also be used
- No additional guide rail is required
- The linear units should not be exposed to tensile forces
- The linear unit is supplied with a 9ft 10" (3m) hydraulic hose pre-fitted as standard
- Plain anodized aluminum

Type LA|LD|LG

	Lift	A
LA LD 1415	6" (150 mm)	10" (252 mm)
LA LD 1420	8" (200 mm)	13" (317 mm)
LA LD LG 1430	17" (442 mm)	18" (463 mm)
LA LD LG 1440	21" (542 mm)	22" (563 mm)
LA LD 1450	20" (500 mm)	26" (667 mm)
LA LD 1460	24" (600 mm)	30" (767 mm)
LA LD 1470	28" (700 mm)	34" (867 mm)

Detailed CAD drawings in various formats can be found at www.ergoswiss.us



Robust and versatile

The table leg **TA** is ideal for assembly work stations, workbenches, office desks, built-in kitchens or in combination with aluminum profile systems with high load and stability requirements.

Crossbars or mounting brackets are fitted on the welded-on mounting plate. The table plate supports, crossbars and mounting brackets are supplied with all the necessary screws.

The height is adjusted by means of a hydraulic pump operated by a hand crank or an electric drive unit.

The 13ft (4 m) long hydraulic hose is already mounted on the table leg and vented to ensure easy assembly.

The following accessories are available:

- table plate supports for mounting the table top
- crossbars of various lengths
- adjustable feet made of rubber or aluminum
- castor incl. brake
- table leg with assembly plates on both sides
- table feet, base plates

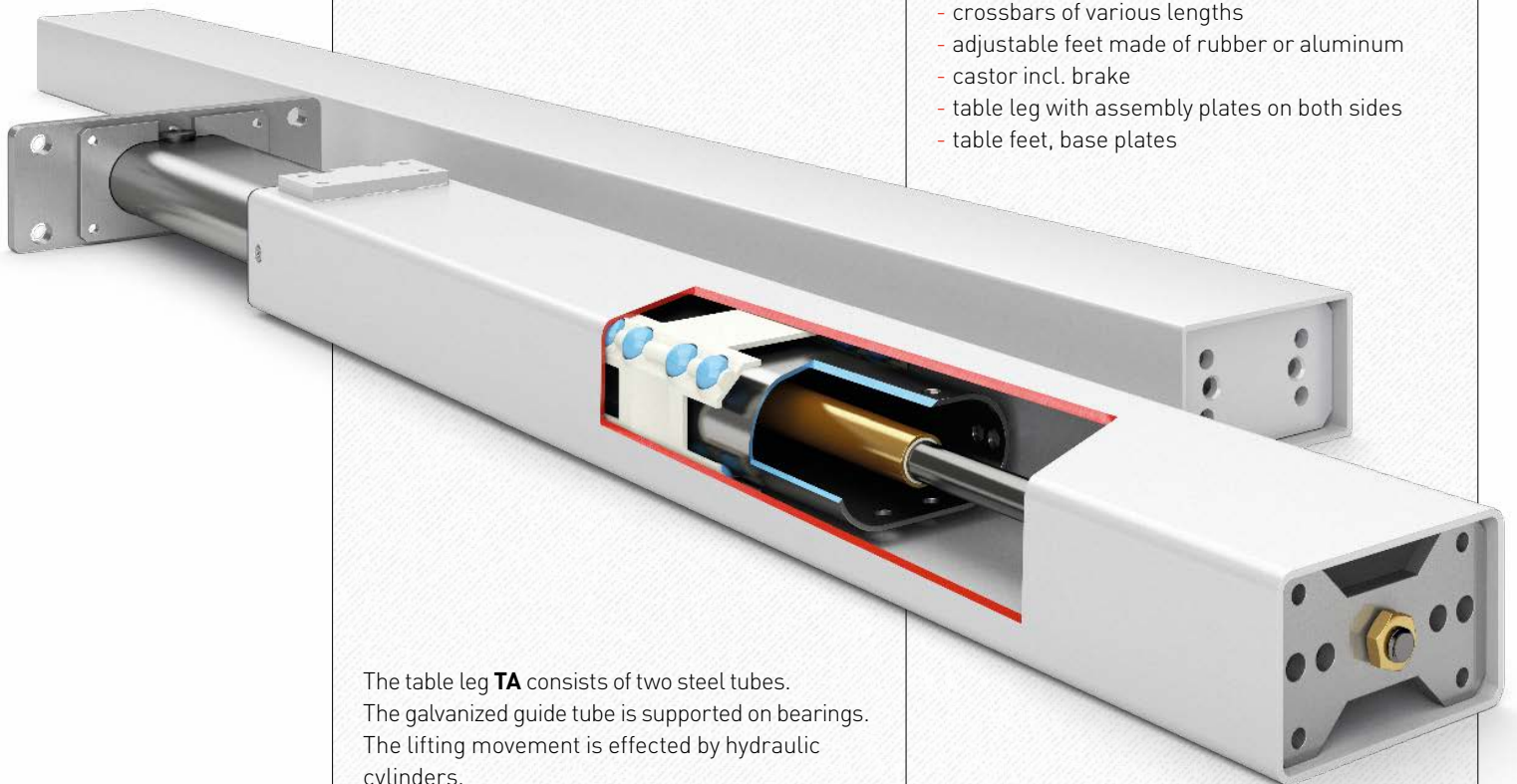

The table leg **TA** consists of two steel tubes. The galvanized guide tube is supported on bearings. The lifting movement is effected by hydraulic cylinders.

Dimensions of TA

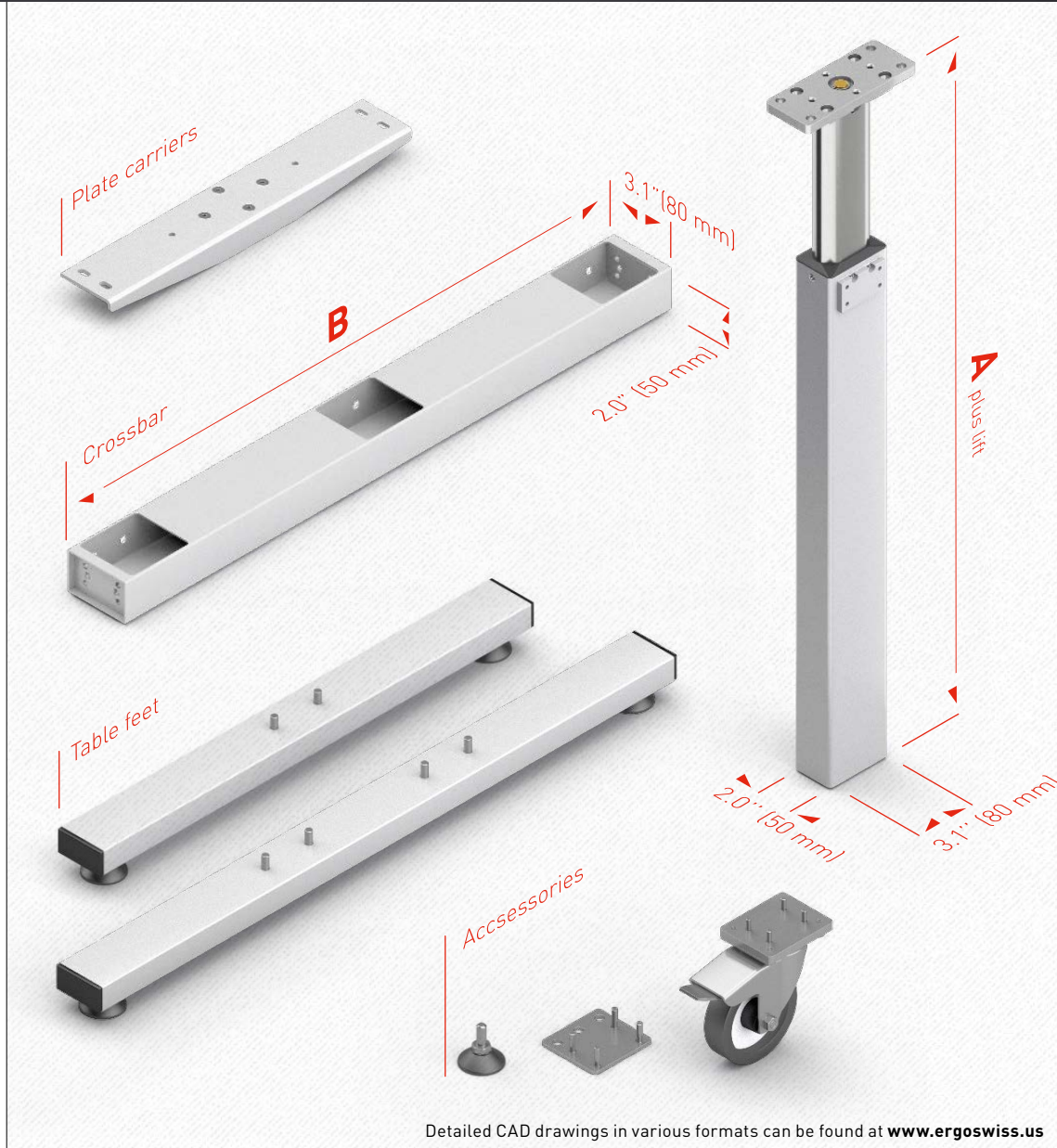

Technical data

- Robust leg with ball track
- Please also note the maximum load of the entire system
- Max. load per leg:
330 lbs (150 kg) (TA 14)
550 lbs (250 kg) (TA 18)
- Lifting distance max.
120" (500 mm)
- Max. static bending moment
 $M_b = 250 \text{ lbf ft}$ (400 Nm)
- Max. dynamic bending moment
 $M_{b\text{dyn}} = 70 \text{ lbf ft}$ (100 Nm)
- The leg is supplied with a 13ft (4 m) long hydraulic hose pre-fitted as standard
- Colour: RAL 9006 white aluminum
- Other models on request

Table leg TA

	A	Lift
TA 1430	16" (415 mm)	12" (300 mm)
TA 1440	20" (515 mm)	16" (400 mm)
TA 1450	25" (640 mm)	20" (500 mm)

Crossbar TA

	B
TA 550	22" (550 mm)
TA 750	30" (750 mm)
TA 950	37" (950 mm)
TA 1150	45" (1150 mm)
TA 1550	61" (1550 mm)

Detailed CAD drawings in various formats can be found at www.ergoswiss.us

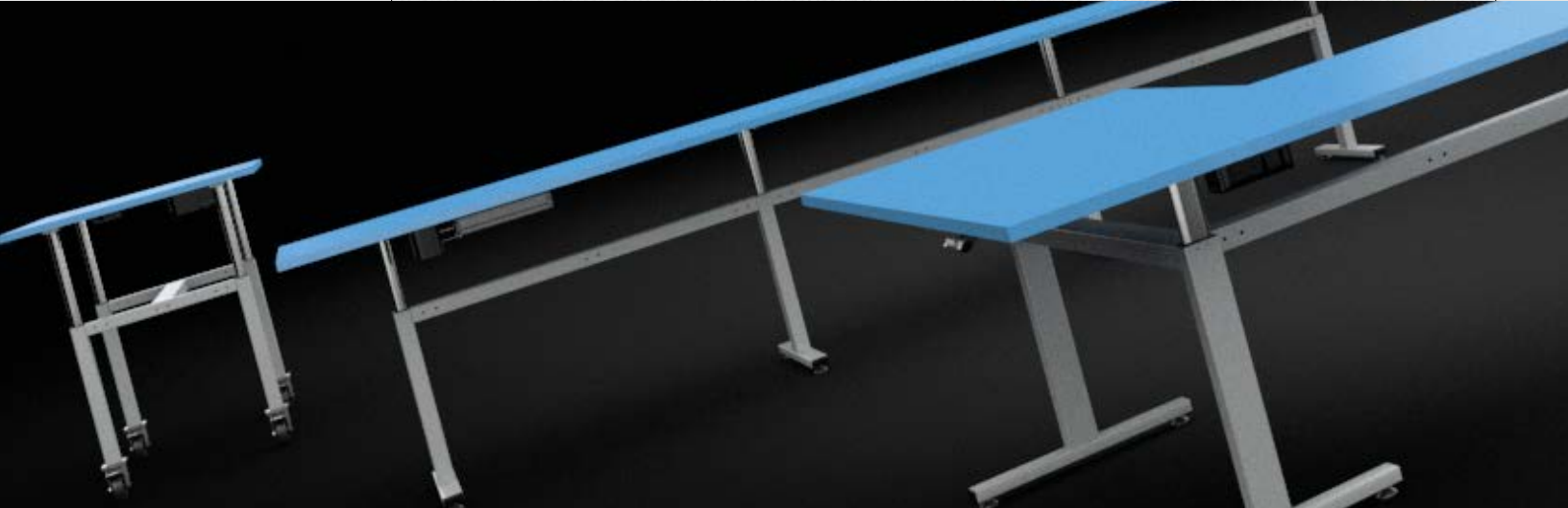

The **TA** base frame is a modular system and is therefore very versatile and flexible in its application.

The maximum load is 770 lb, 1320 lbs or 1760 lbs (350 kg, 600 kg or 800 kg) depending on the system combination. Thanks to the large lifting distance of maximum 20" (500 mm), the tables can also be used in a standing position.

TA-2: A two-leg base frame for sitting and standing work stations in the office or at the assembly station. Consisting of two table legs, two table plate supports, two table feet as well as a crossbar to stabilize the base frame. Various table lengths can be realized using the crossbars from the standard programme.

TA-3: A three-leg base frame for corner combinations in the office and in assembly areas. Here, the two-leg system is extended with an additional crossbar and a third leg.

TA-4: A four-leg base frame for maximum stability as required for workbenches, joiner's benches and assembly work stations. The longitudinal crossbar can be placed at three different depth positions.

Various screws to mount the table top are included with your order. The base frame is delivered unassembled.

Please note that a pump with hand crank or electric drive unit is also required.

Assembly and operating instructions are included with every delivery. They can also be downloaded from www.ergoswiss.us



Dimensions of base frame **TA**

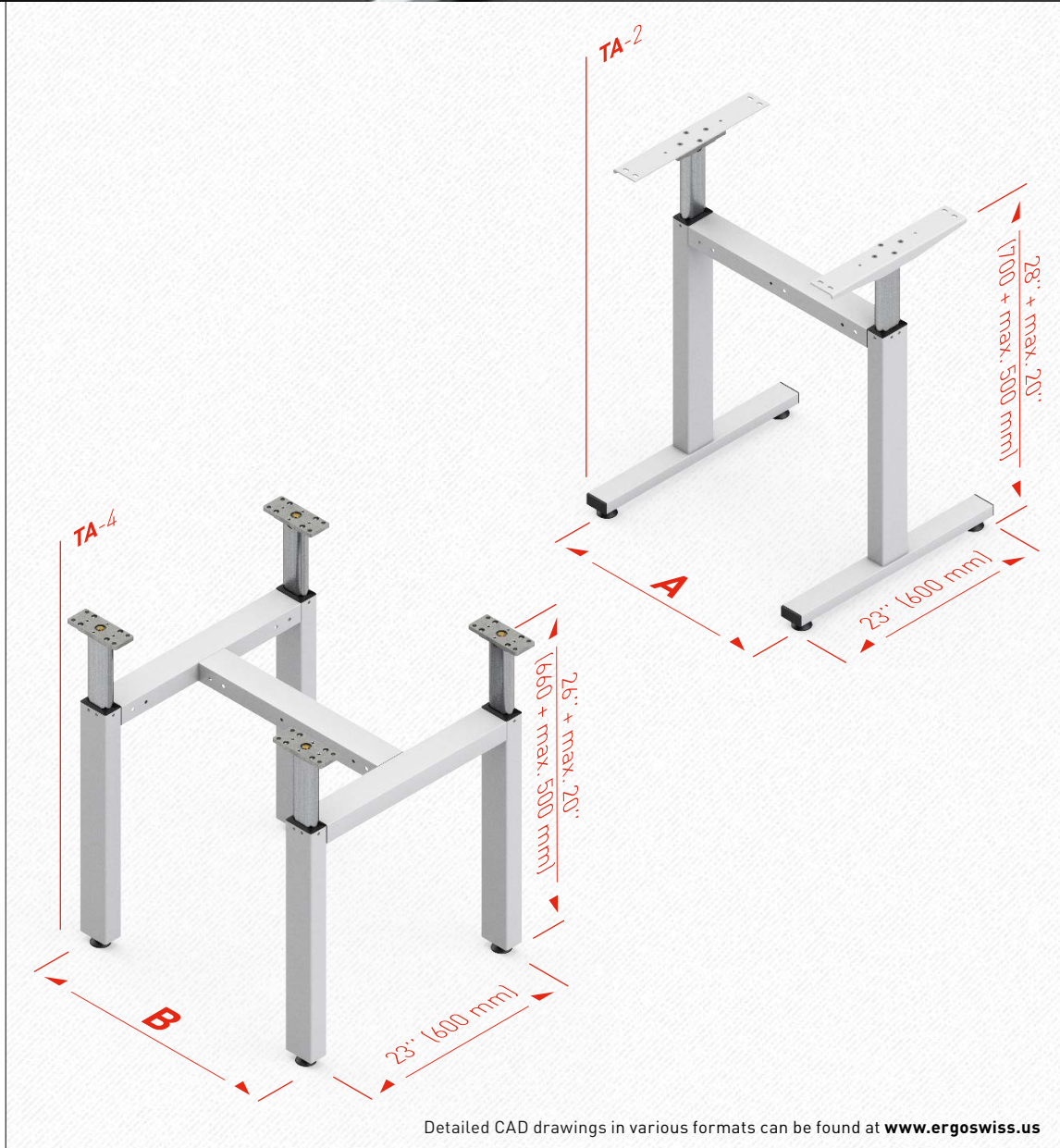

Base frame **TA-2**

	A
TA-2 600	24" (600 mm)
TA-2 1000	39" (1000 mm)
TA-2 1200	47" (1200 mm)
TA-2 1600	63" (1600 mm)

Base frame **TA-4**

	B
TA-4 1030	41" (1030 mm)
TA-4 1230	48" (1230 mm)
TA-4 1630	64" (1630 mm)

Detailed CAD drawings in various formats can be found at www.ergoswiss.us



Elegant and powerful

The table leg **TL** belongs to the same design family as the table legs **TM**, **SL** and **SM**.

Its plain anodized aluminum housings come with a simple surface design to ensure an elegant and stylish finish in all product combinations.

The T-slots on 3 sides (0.3" or 8 mm) allow the addition of crossbars, shelves and other attachments along the entire length of the leg. The table legs **TL** and **TM** are the same length and can therefore easily be combined with one another.

This design family also has a corresponding range of accessories to use in combination.

Application

The table leg **TL** is used for 2-leg base frames, while the table leg **TM** tends to be used when a crank drive or several table legs are required. Up to 10 table legs can be driven up and down at the same time. The hydraulic pump can be operated either by using a hand crank or electronically via cable remote control.

The lifting columns **SL** and **SM** are recommended for 2 and 4-leg base frames as an alternative to the table leg **TL/TM**. For further information on the lifting columns **SL** and **SM**, please see our Spindle Lifting Systems catalogue.

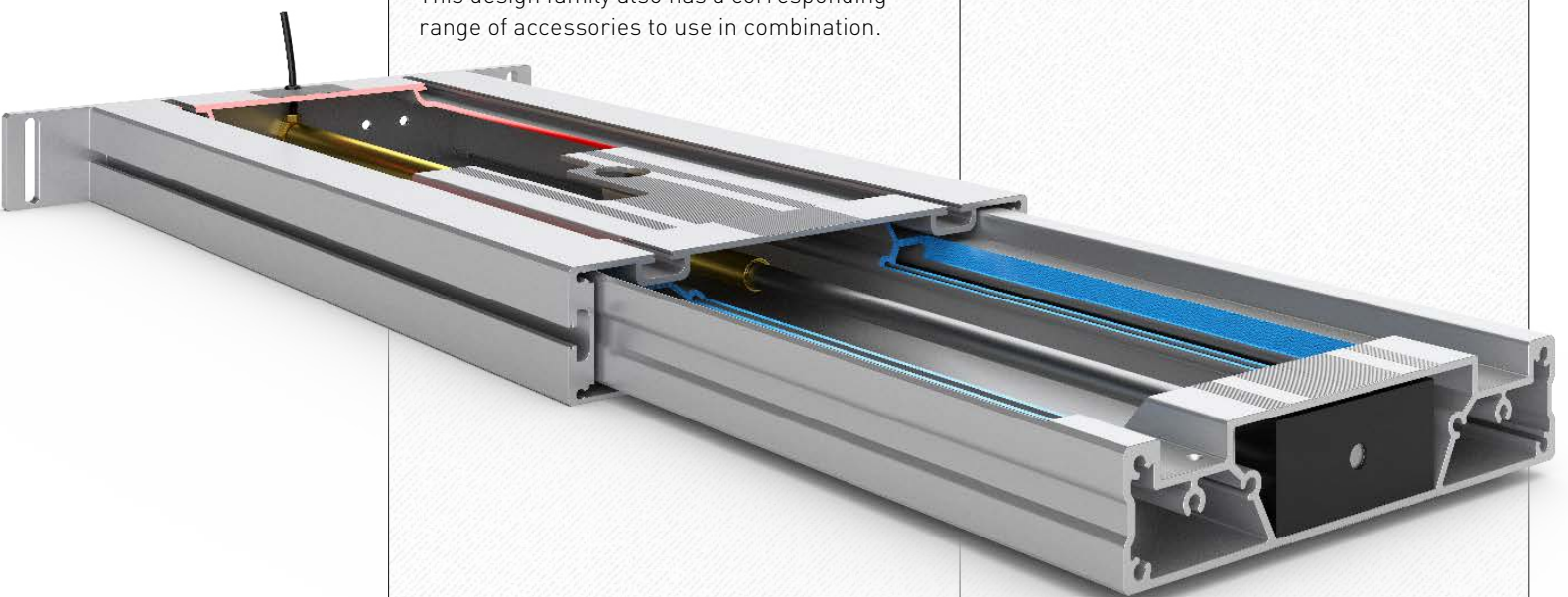

Dimensions of TL

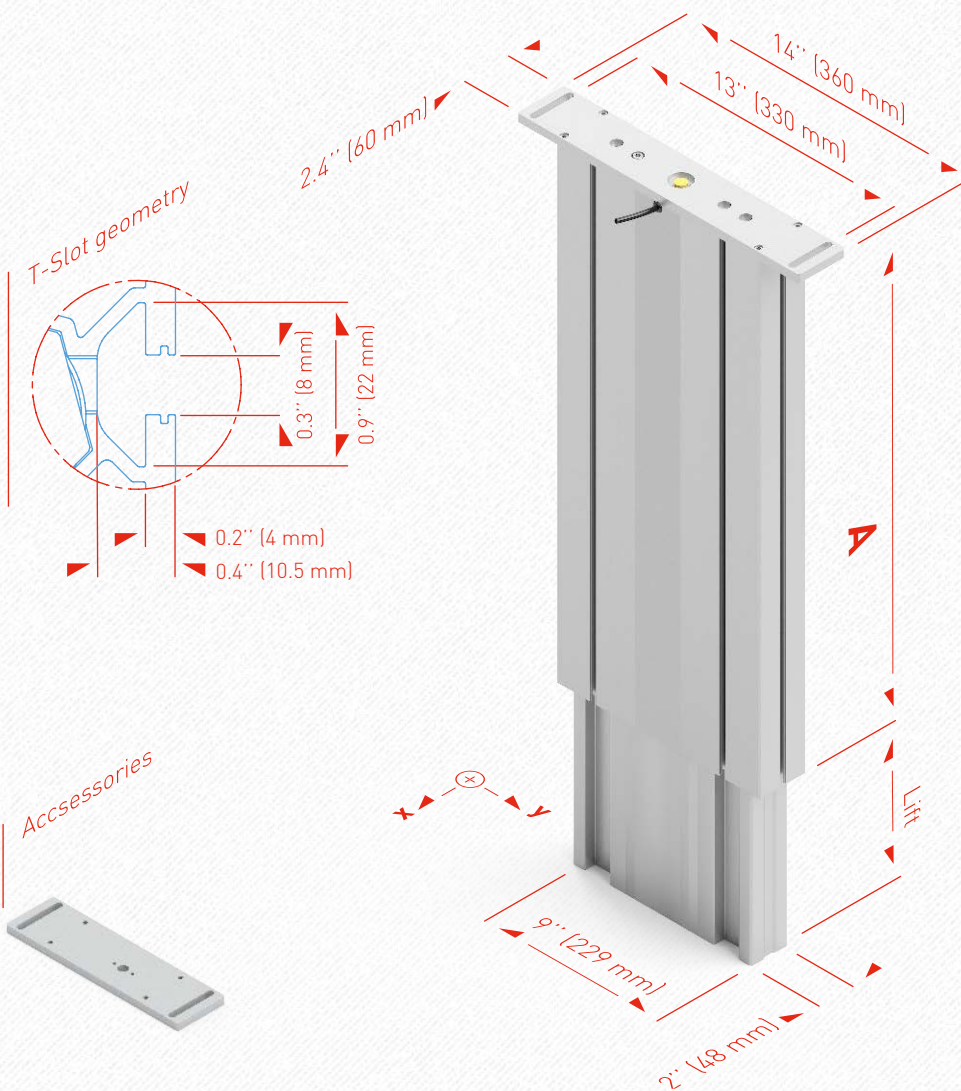

Detailed CAD drawings in various formats can be found at www.ergoswiss.us

Technical data

- Table leg for flexible use with sliding guide
- Max. load per leg:
 - 330 lbs (150 kg) (TL 14)
 - 550 lbs (250 kg) (TL 18)
- Synchronous operation of up to 10 legs possible per pump
- The lifting speed depends on the pump used
- Lifting distance 12" or 16" (300 or 400 mm)
- M_{bx} stat. = 880 lbf ft (1200 Nm)*
- M_{by} stat. = 330 lbf ft (450 Nm)**
- M_{bx} dyn. = 400 lbf ft (550 Nm)*
- M_{by} dyn. = 140 lbf ft (200 Nm)**
- Colour: plain anodized aluminum

* M_{b} stat. = max. permissible bending moment at rest

** M_{b} dyn. = max. permissible bending moment during lifting movement

Table leg TL		
	A	Lift
TL 1430	21" (530 mm)	12" (300 mm)
TL 1440	25" (630 mm)	16" (400 mm)
TL 1830	21.1" (537 mm)	12" (300 mm)
TL 1840	25" (637 mm)	16" (400 mm)



Flexible assembly

Our base frame **TL** is designed for the fast and flexible assembly of tables.

The maximum load is 660 lbs to 1760 lbs (300 kg to 800 kg depending on the system combination). Thanks to the large lifting distance of maximum 16" (400 mm), the tables can also be used in a standing position.

The **TL** base frame consists of 2 table legs, a crossbar and 2 table feet. The crossbars slide easily into the grooves of the lifting columns and are fastened in place with an Allen key.

Various screws to mount the table top are included with your order. The base frame is delivered unassembled.

Assembly and operating instructions are included with every delivery. They can also be downloaded from www.ergoswiss.us.

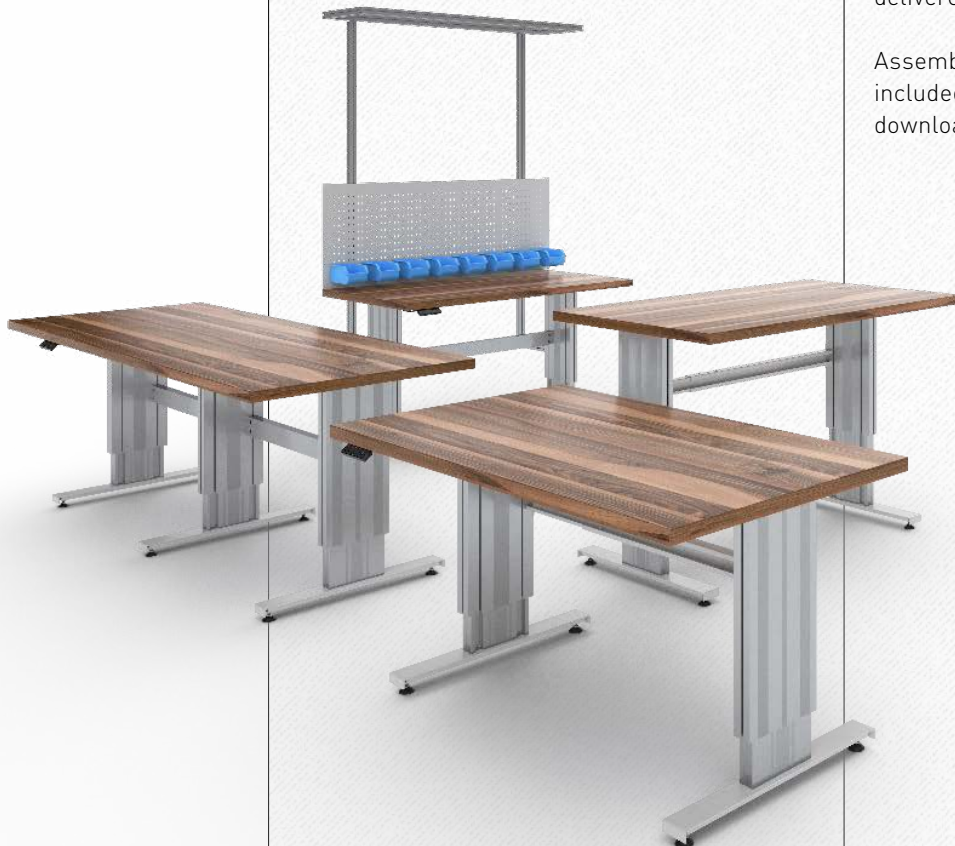

Dimensions of base frame TL

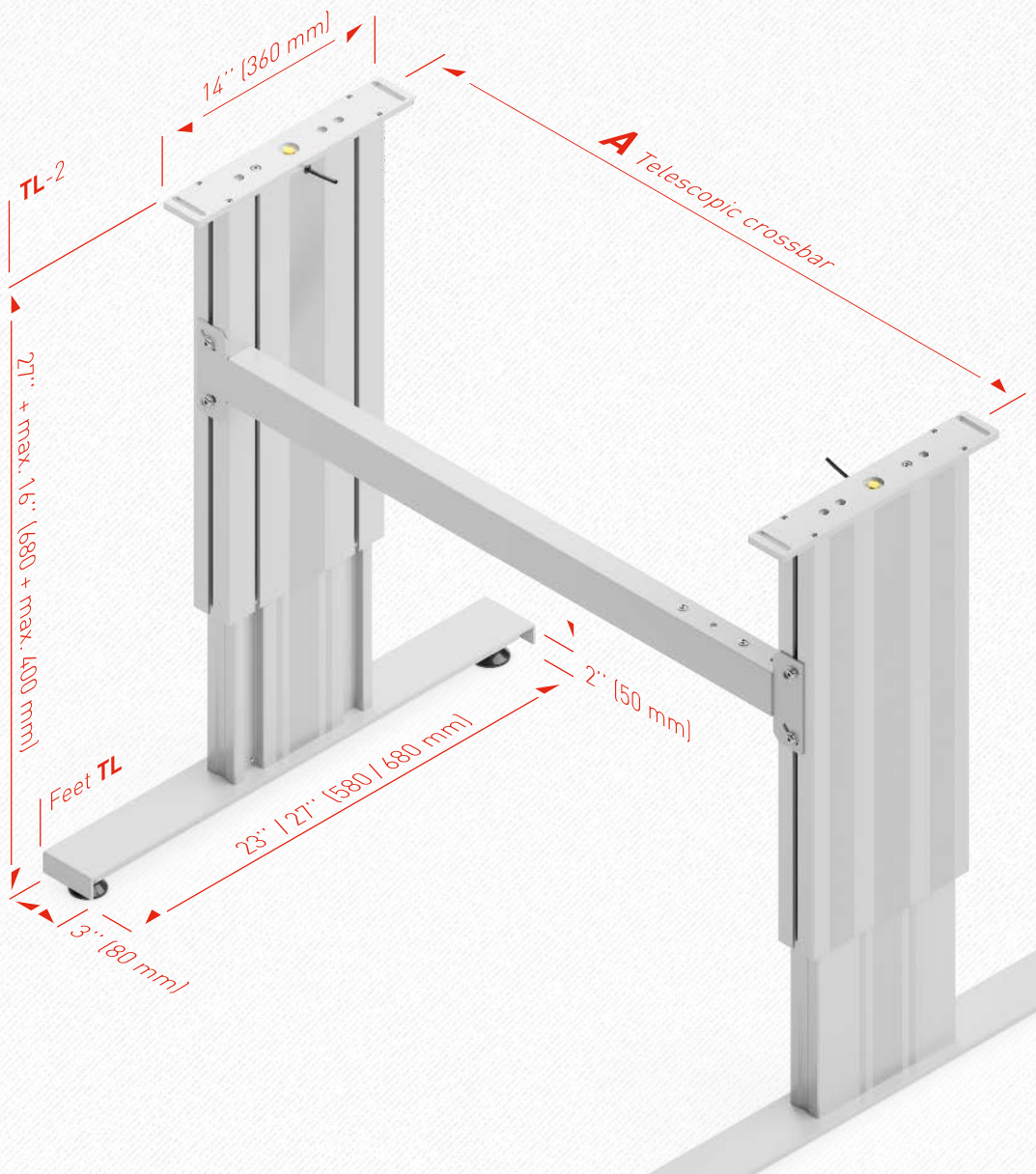

Base frame TL-2

	A
TL-2	37" - 63" (960 - 1610 mm)

The telescopic crossbar is adjustable in 2" (50 mm) increments.

The telescopic crossbar can be fitted directly on the outer slot using the slot nuts supplied.

Smaller dimensions are available on request.

Detailed CAD drawings in various formats can be found at www.ergoswiss.us



Slim and robust

The table leg **TM** belongs to the same design family as the table legs TL, SL and SM.

Its plain anodized aluminum housings come with a simple surface design to ensure an elegant and stylish finish in all product combinations.

The T-slots on 3 sides (width 0.3" or 8 mm) allow the addition of crossbars, shelves and other attachments along the entire length of the leg. The table legs **TM** and TL are the same length and can therefore easily be combined with one another.

This design family also has a corresponding range of accessories to use in combination.

Application

The table leg **TM** tends to be used when a crank drive or several table legs are required. Up to 10 table legs can be activated at the same time. The hydraulic pump can be operated either by using a hand crank or electronically via cable remote control.

For base frames with 2 legs, we recommend table leg TL or SL. The lifting column SM is equipped for base frames with 4 legs. For further information on the lifting columns SM and SL, please see our Spindle Lifting Systems catalogue.

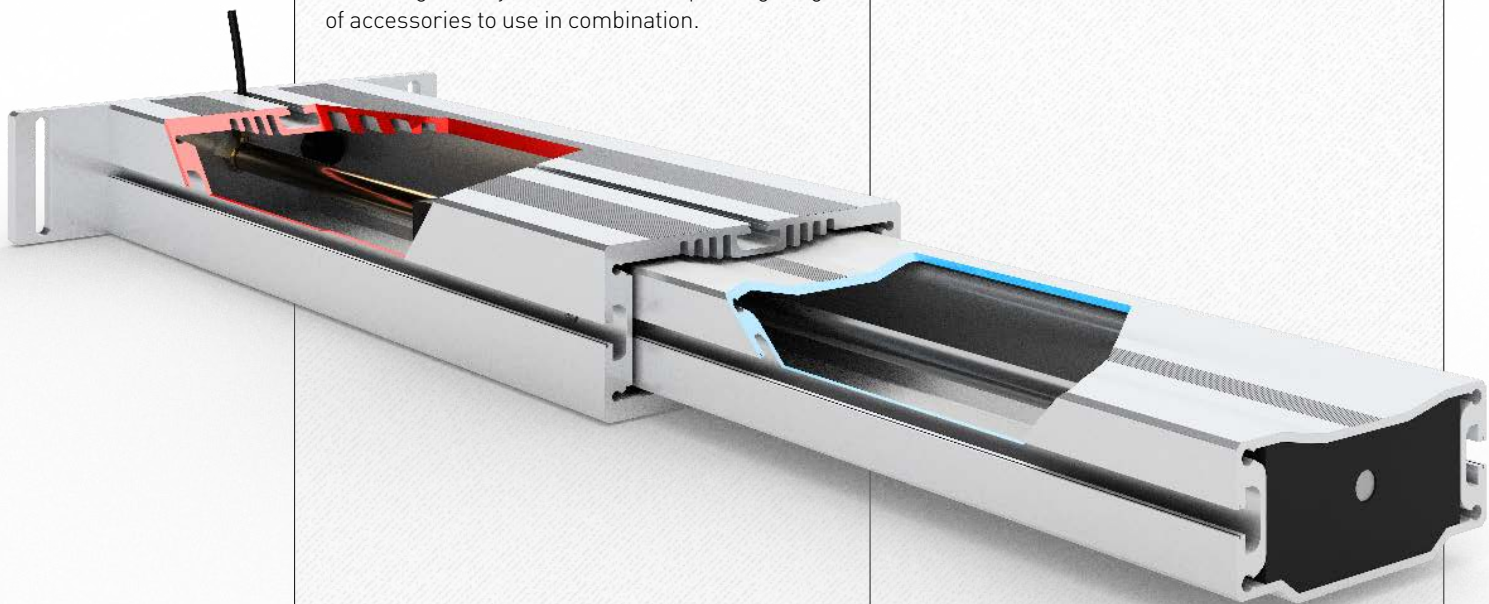

Dimensions of **TM**

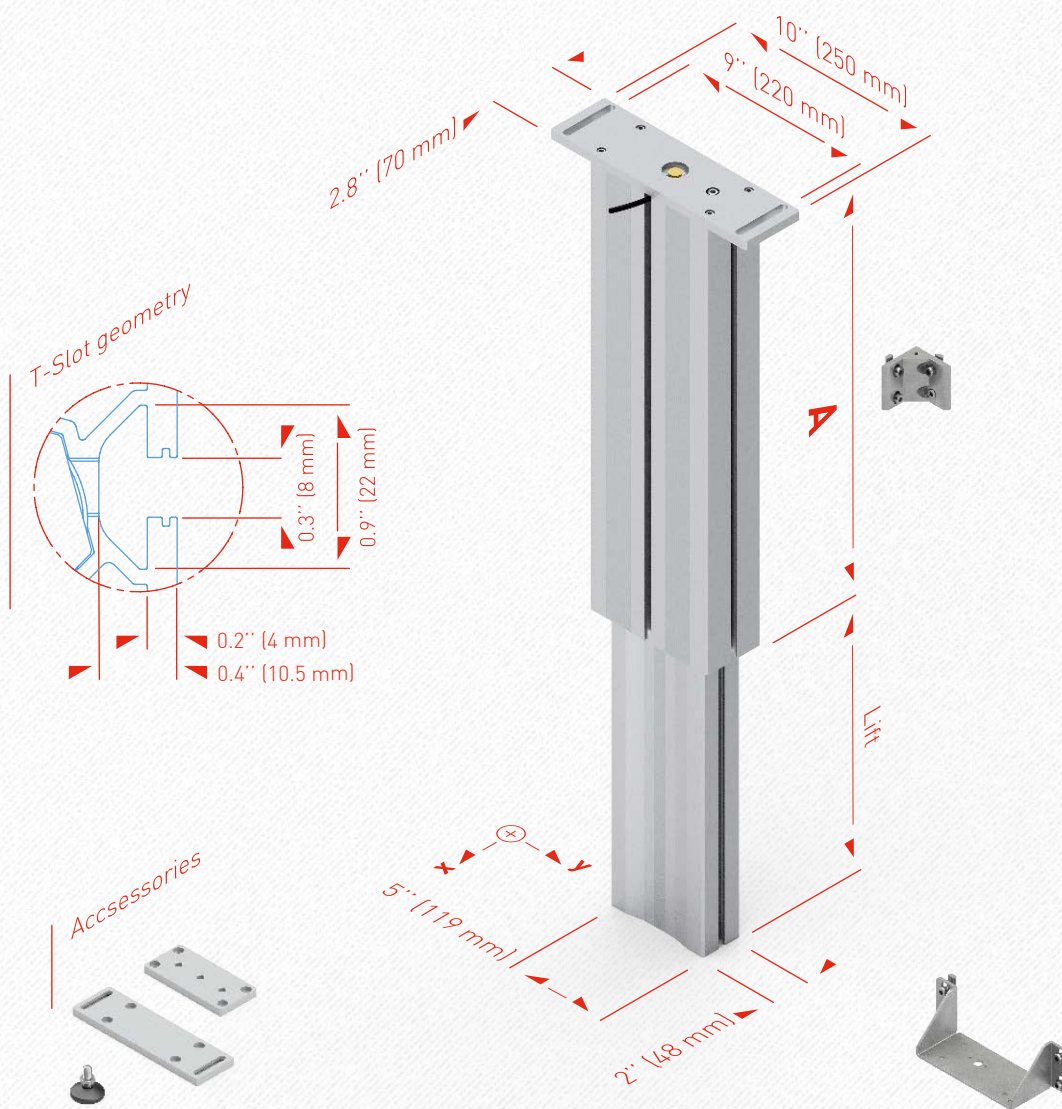

Technical data

- Table leg for flexible use with sliding guide
- Max. load per leg:
 - 330 lbs (150 kg) (**TM 14**)
 - 550 lbs (250 kg) (**TM 18**)
- Synchronous operation of up to 10 legs possible per pump
- Lifting distance 12" or 16" (300 or 400 mm)
- The lifting speed depends on the pump used
- M_{bx} stat. = 660 lbf ft (900 Nm)*
 M_{by} stat. = 250 lbf ft (350 Nm)**
- M_{bx} dyn. = 330 lbf ft (450 Nm)*
 M_{by} dyn. = 110 lbf ft (150 Nm)**
- Colour: plain anodised aluminium

* M_{b} stat. = max. permissible bending moment at rest

** M_{b} dyn. = max. permissible bending moment during lifting movement

Table leg TM		
	A	Lift
TM 1430	21" (530 mm)	12" (300 mm)
TM 1440	25" (630 mm)	16" (400 mm)
TM 1830	21.1" (537 mm)	12" (300 mm)
TM 1840	25" (637 mm)	16" (400 mm)

Detailed CAD drawings in various formats can be found at www.ergoswiss.us



Combinable in a variety of ways



The base frame **TM-2** consists of two table legs **TM**, each of which is mounted on a table foot with adjustable feet and connected by a crossbar. Each table leg **TM** is equipped with a table plate support which is used to attach the table top.

- Ideal for office desks or light assembly tables

The base frame **TM-4** consists of four table legs **TM**, arranged in a rectangle and connected by crossbars. The table legs are equipped with a foot plate including adjustable rubber feet. The table top is attached directly to the adapter plates of the table legs **TM**.

- Ideal for stable workbenches

Assembly and operating instructions are included with every delivery. They can also be downloaded from www.ergoswiss.us.



Dimensions of base frame **TM**

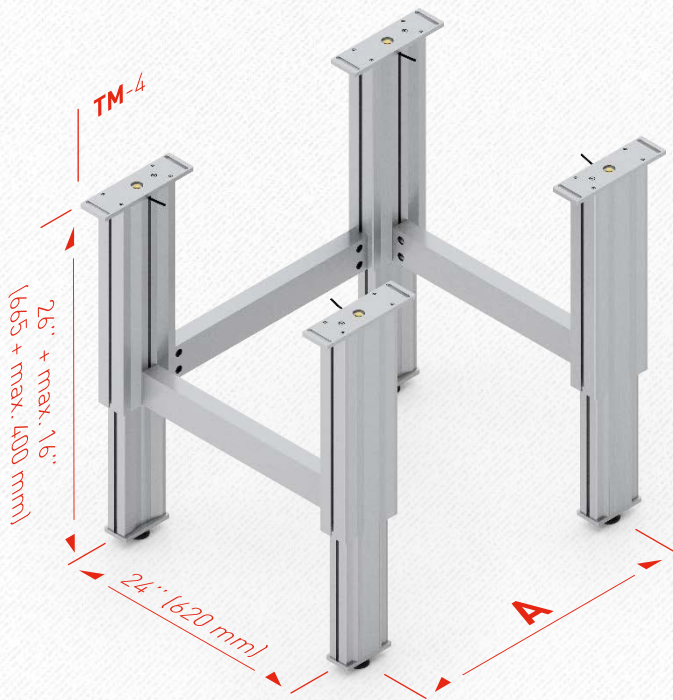

Base frame **TM-4**

	A
TM-4	28" (700 mm)
TM-4	43" (1000 mm)
TM-4	51" (1300 mm)
TM-4	67" (1700 mm)

The telescopic crossbar is adjustable in 2" (50 mm) increments.

The telescopic crossbar can be fitted directly on the outer slot using the slot nuts supplied.

Smaller dimensions are available on request.

Detailed CAD drawings in various formats can be found at www.ergoswiss.us



Elegant and versatile

The table leg **TT** can be used for assembly tables, in assembly units, for office desks, height-adjustable beds and baths and for general use in furniture construction and mechanical engineering.

The T-slots on 3 sides (width 0.3" or 8 mm) allow the addition of crossbars, shelves and other attachments and mountings along the entire length of the leg. Corner combinations and interlinked work stations can also be designed in combination with the **PB** and **PF** pump.

The table leg **TT** consists of two extruded aluminum profiles with a plain anodized finish, guided by plastic gliders. The lifting movement is effected by hydraulic cylinders.

The height is adjusted by means of a hydraulic pump operated by a hand crank or an electric drive unit.

The 9ft 10" (4m) -long high-pressure hose is already mounted on the table leg and vented to ensure easy assembly.

The following accessories are available:

- telescopic crossbar
- table feet with adjustable rubber feet
- base plates
- option: ESD version

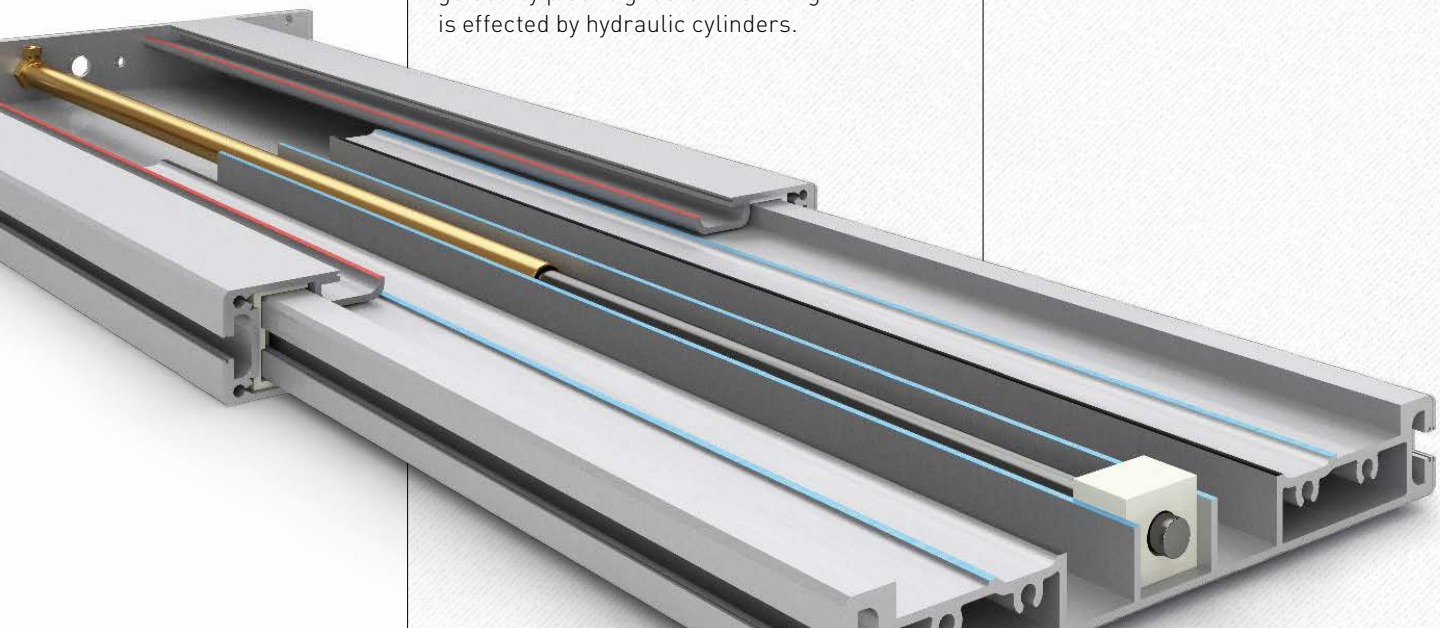

Dimensions of TT

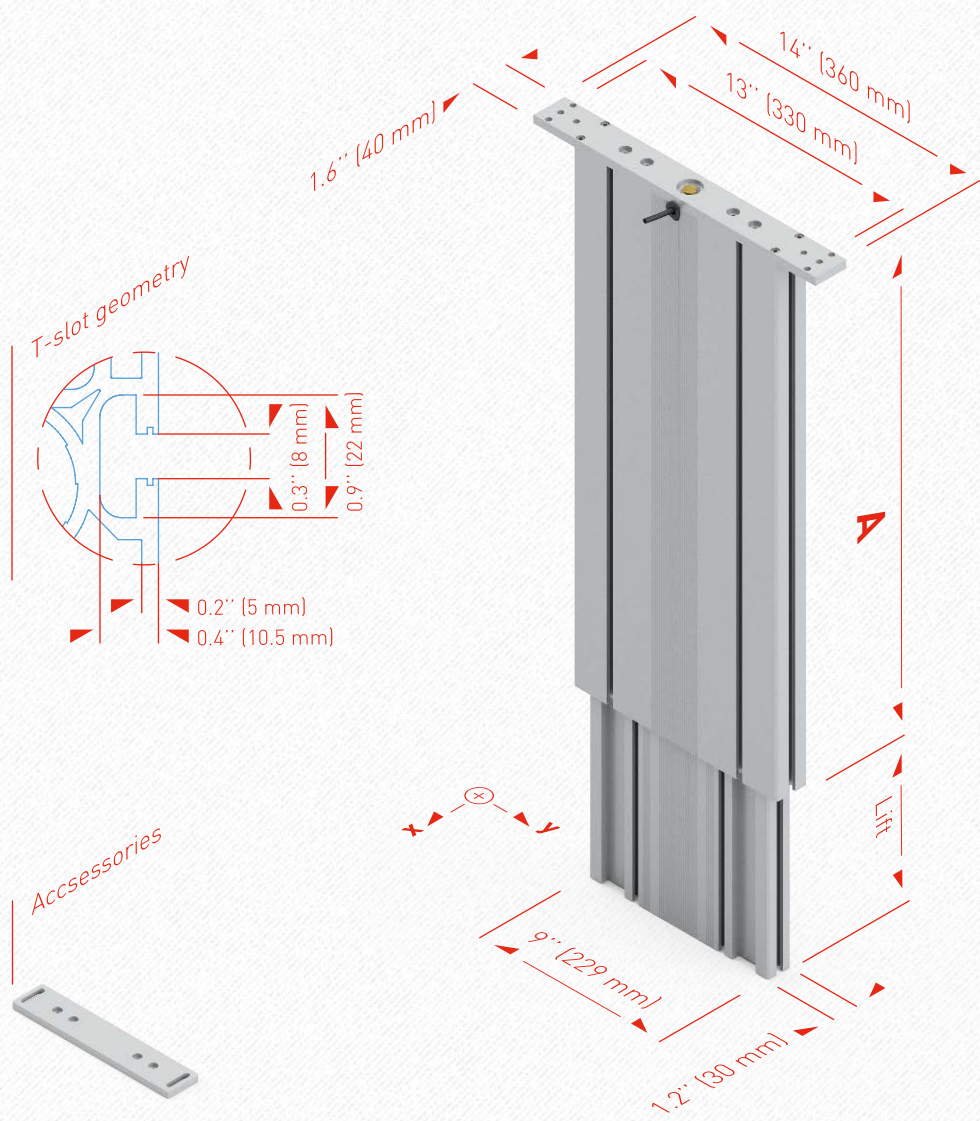

Technical data

- Table leg for flexible use with sliding guide
 - Max. load per leg:
330 lbs (150 kg) (**TT 14**)
550 lbs (250 kg) (**TT 18**)
 - Please also note the maximum load of the entire system
 - Synchronous control of up to 10 table legs
 - Lifting distance max.
12" or 16" (300 or 400 mm)
 - The lifting speed depends on the pump used
 - Mb_x stat. =
730 lbf ft (1000 Nm)*
Mb_y stat. =
220 lbf ft (300 Nm)**
 - Mb_x dyn. =
330 lbf ft (450 Nm)*
Mb_y dyn. =
110 lbf ft (150 Nm)**
 - Plain anodized aluminum
- * Mb stat. = max. permissible bending moment at rest
** Mb dyn. = max. permissible bending moment during lifting movement

Table leg TT

	A	Lift
TT 1430	21" (530 mm)	12" (300 mm)
TT 1440	25" (630 mm)	16" (400 mm)
TT 1830	21" (537 mm)	12" (300 mm)
TT 1840	25" (637 mm)	16" (400 mm)



Our base frame **TT** is designed for the fast and flexible assembly of tables.

The maximum load is 660 lbs to 1100 lbs (300 kg to 500 kg depending on the pump version). The max. height adjustment range is 16" (400 mm).

The **TT-2** base frame consists of 2 table legs, a crossbar and 2 table feet. The crossbars slide easily into the grooves of the table legs and are fastened in place with an Allen key. Various screws to mount the table top are included with your order. The base frame is delivered unassembled.

Please note that a pump with hand crank or electric drive unit is also required.

Assembly and operating instructions are included with every delivery. They can also be downloaded from **www.ergoswiss.us**.



Dimensions of base frame **TT**

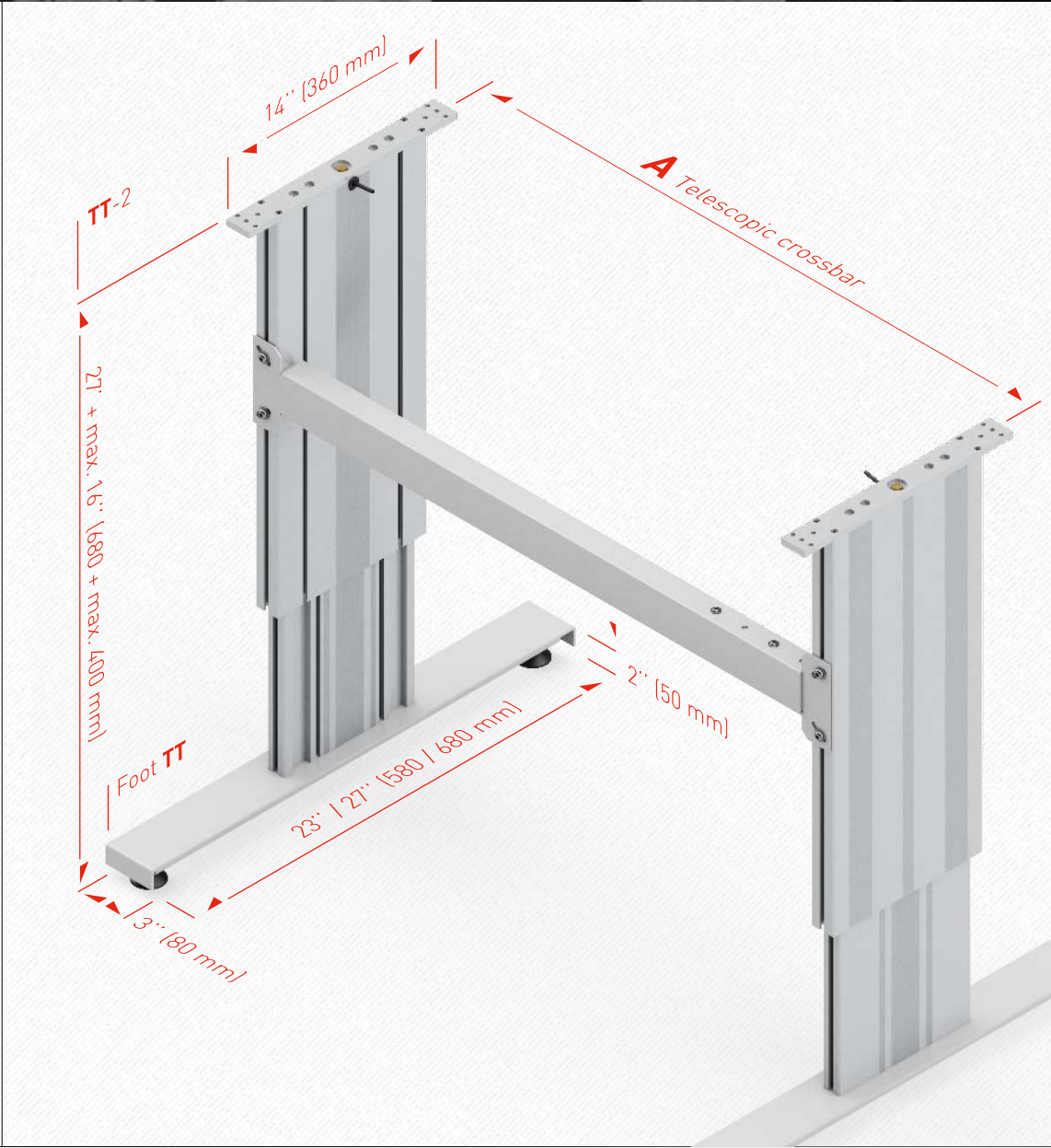
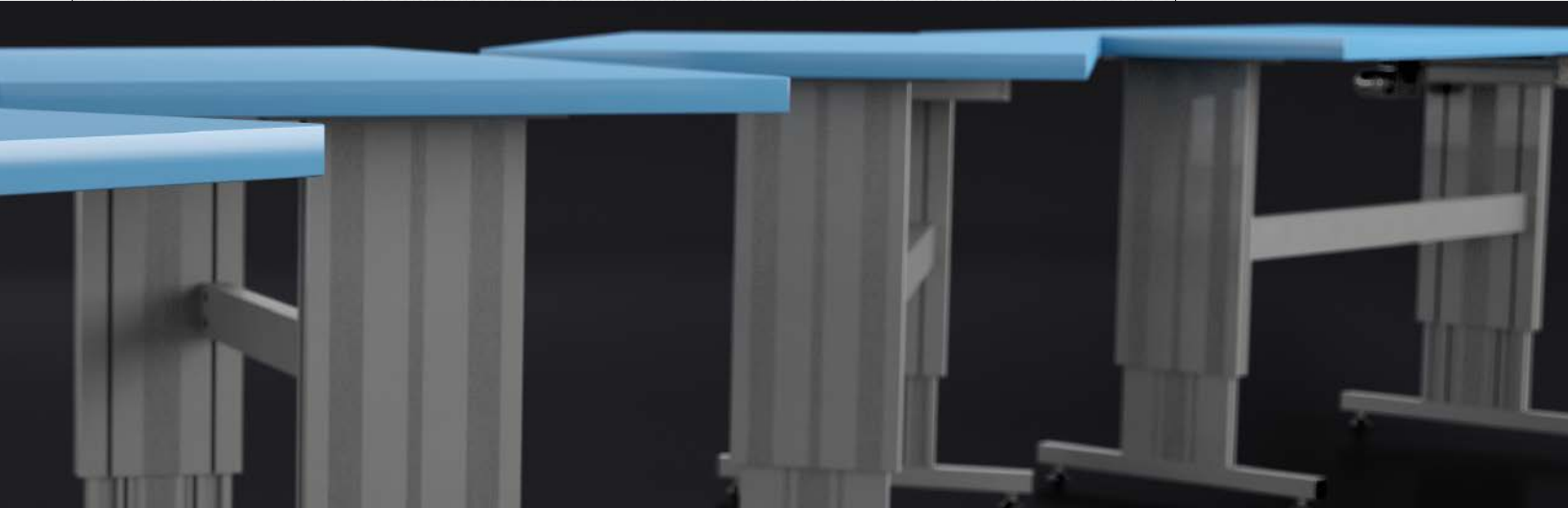

Base frame **TT-2**

	A
TT-2	37" - 62.6" (940 - 1590 mm)

The telescopic crossbar is adjustable in 2" (50 mm) increments.

The telescopic crossbar can be fitted directly on the outer slot using the slot nuts supplied.

Smaller dimensions are available on request.

Detailed CAD drawings in various formats can be found at www.ergoswiss.us.

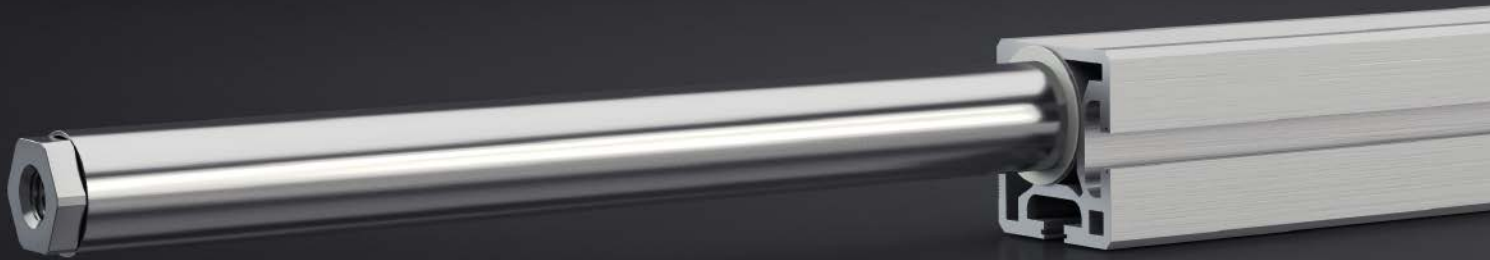

Elegant and versatile

The table leg **TQ** is ideal for assembly work stations made from aluminum profiles and as a base for multi-leg conveyor lines.

The T-slots (width 0.3" or 8 mm) allow the addition of crossbars, shelves and other attachments and mountings along the entire length of the leg.

The height is adjusted by means of a hydraulic pump operated by a hand crank or an electric drive unit.

The 13ft (4 m) long hydraulic hose is already mounted on the table leg and vented to ensure easy assembly.

The following accessories are available:

- crossbars of various lengths
- adjustable feet made of rubber or aluminum
- locking castors (load 150 lbs or 70 kg)

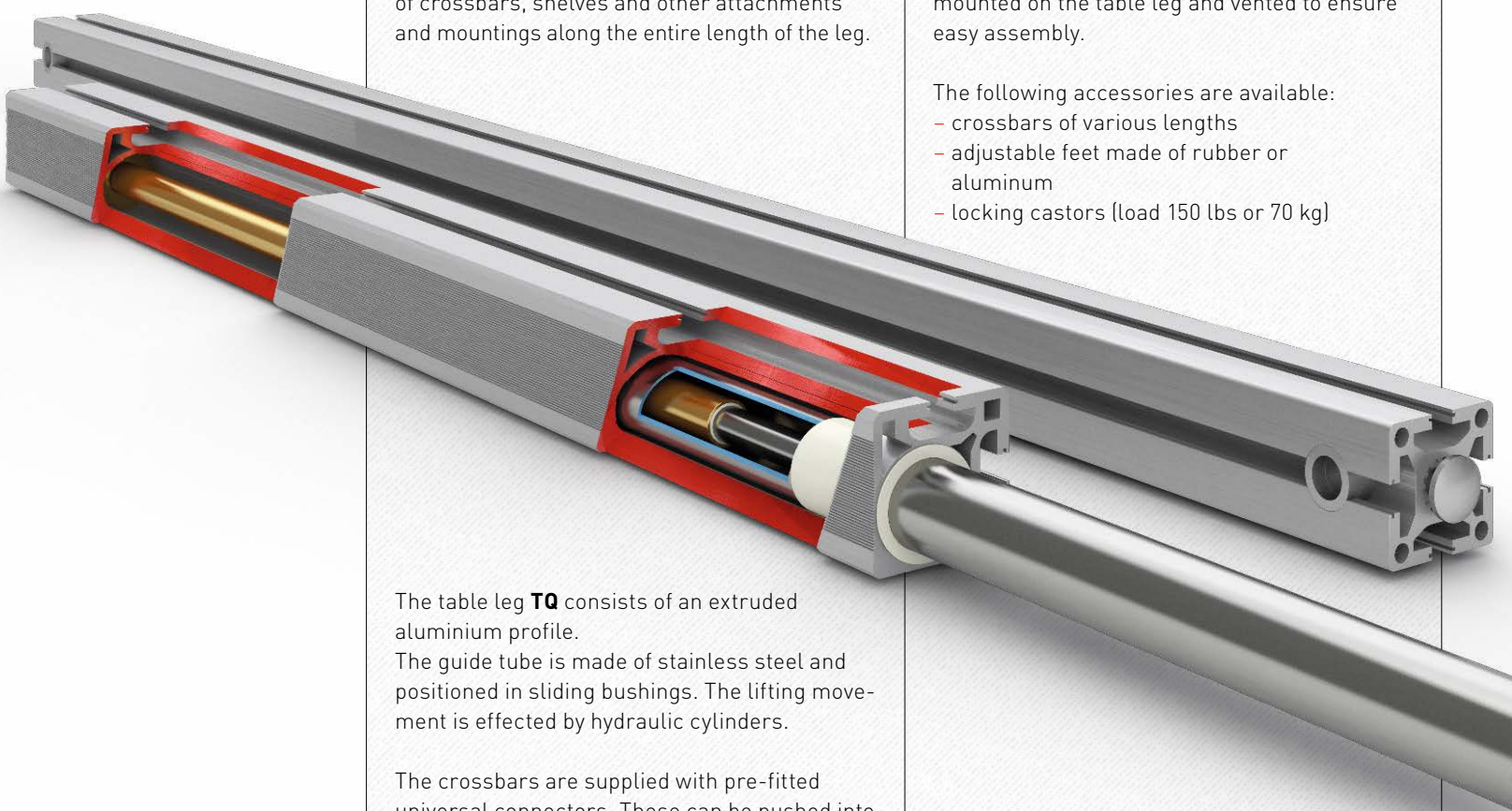

The table leg **TQ** consists of an extruded aluminium profile. The guide tube is made of stainless steel and positioned in sliding bushings. The lifting movement is effected by hydraulic cylinders.

The crossbars are supplied with pre-fitted universal connectors. These can be pushed into the table legs and fastened in place with a conical screw connection.

Dimensions of TQ

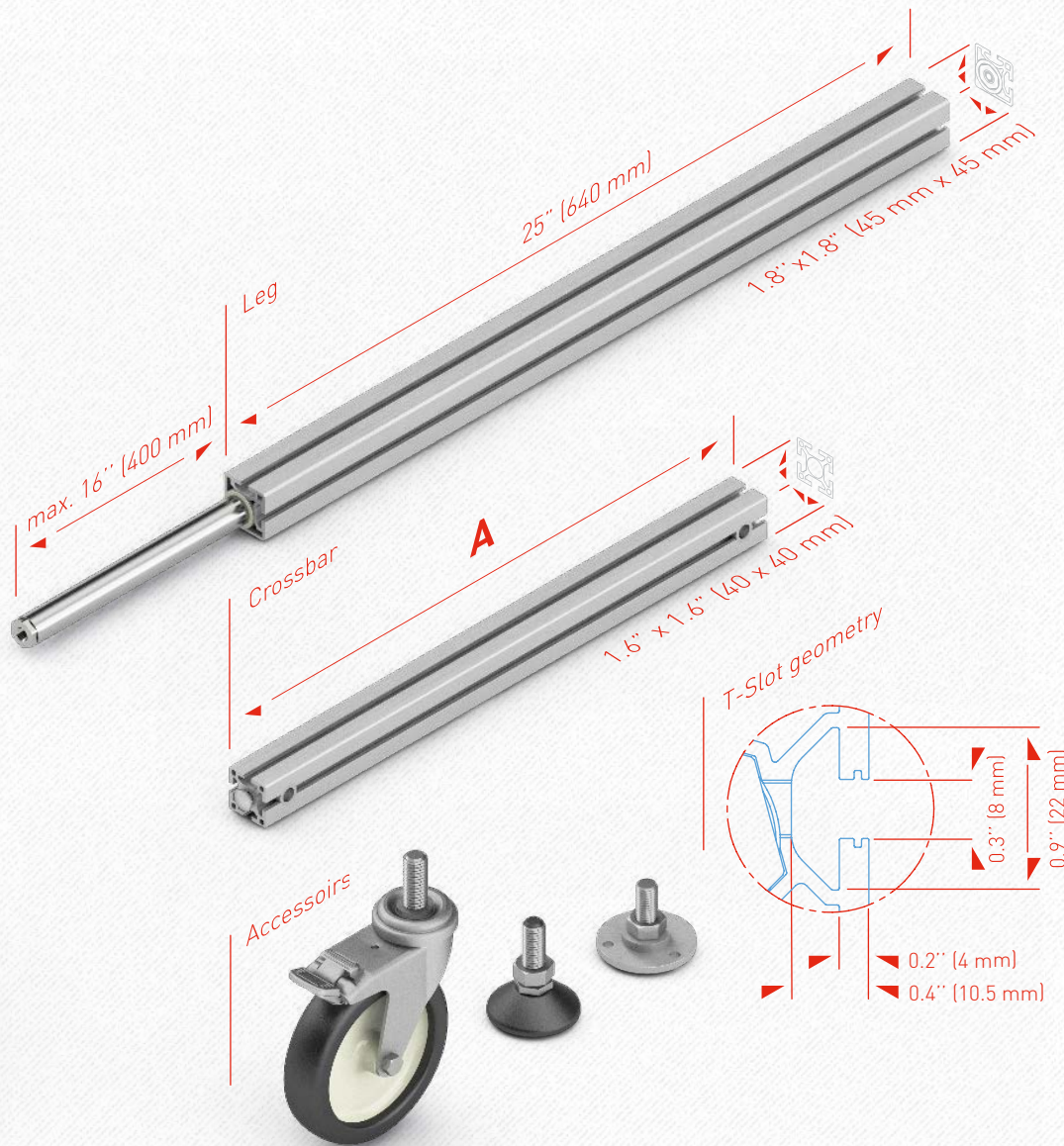

Technical data

- Table leg for flexible use with sliding guide
- Max. load per leg:
330 lbs (150 kg) (TT 14)
550 lbs (250 kg) (TT 18)
- The system load depends on the pump used
- Lifting distance max. 16" (400 mm)
- **TQ 1830 V** with built-in hose rupture protection
- Max. static bending moment $M_b = 140 \text{ lbf ft}$ (200 Nm)
- Max. dynamic bending moment $M_{bdyn} = 50 \text{ lbf ft}$ (80 Nm)
- Colour:
plain anodized aluminum

Crossbar TQ

	A
TQ 550	22" (550 mm)
TQ 750	30" (750 mm)
TQ 950	37" (950 mm)
TQ 1150	45" (1150 mm)
TQ 1550	61" (1550 mm)



Our base frame **TQ** is designed for the fast and flexible assembly of tables.

The maximum load is 770 lbs to 1320 lbs (350 kg to 600 kg) depending on the pump version. The max. height adjustment range is 16" (400 mm).

The **TQ-4** base frame consists of 4 legs and 7 crossbars. The crossbars slide easily into the grooves of the table legs and are fastened in place with an Allen key. Various brackets and screws to mount the table top are included with your order. The base frame is delivered unassembled.

Please note that a pump with hand crank or electric drive unit is also required.

Assembly and operating instructions are included with every delivery. They can also be downloaded from **www.ergoswiss.us**.



Dimensions of base frame **TQ**

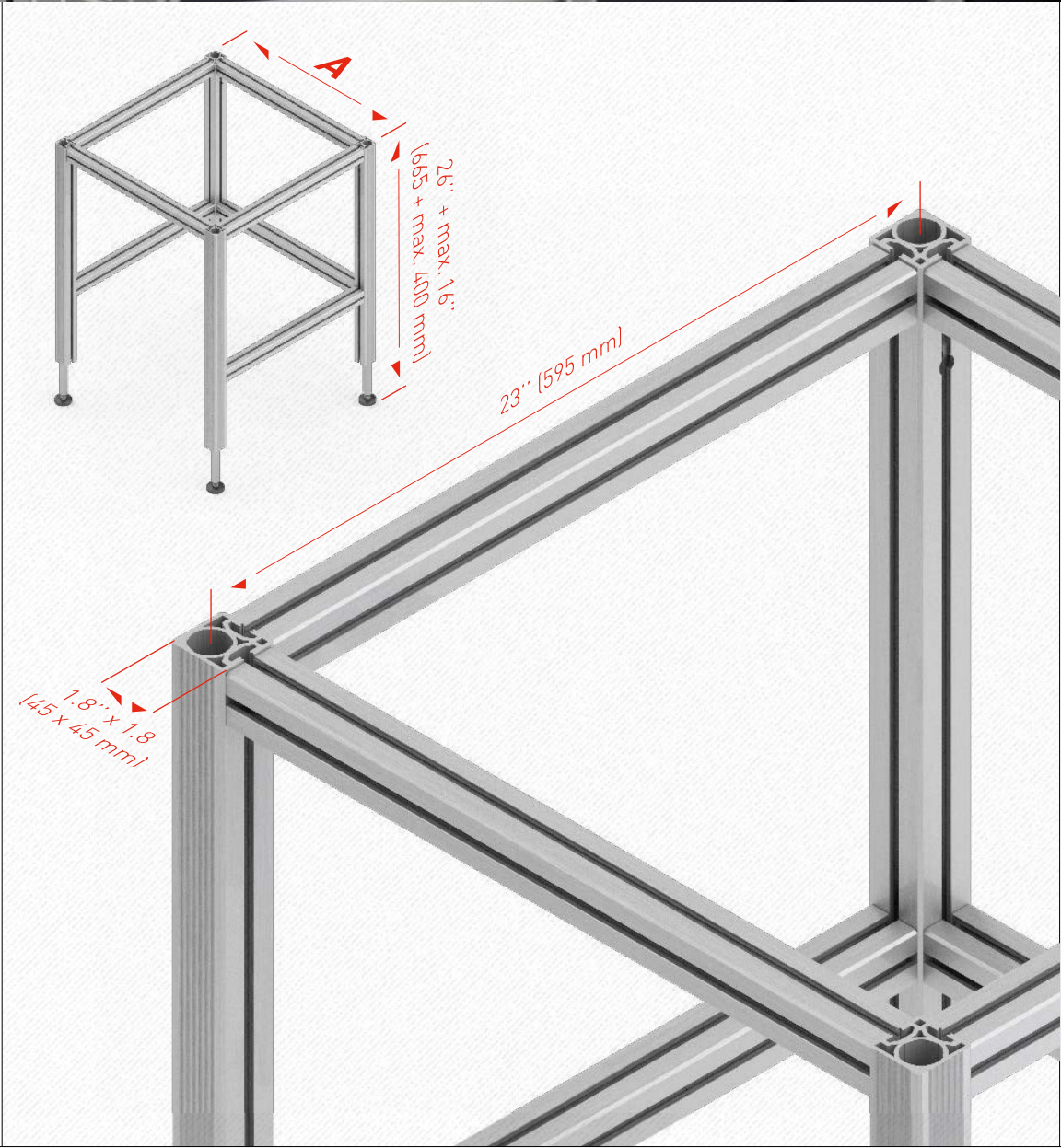
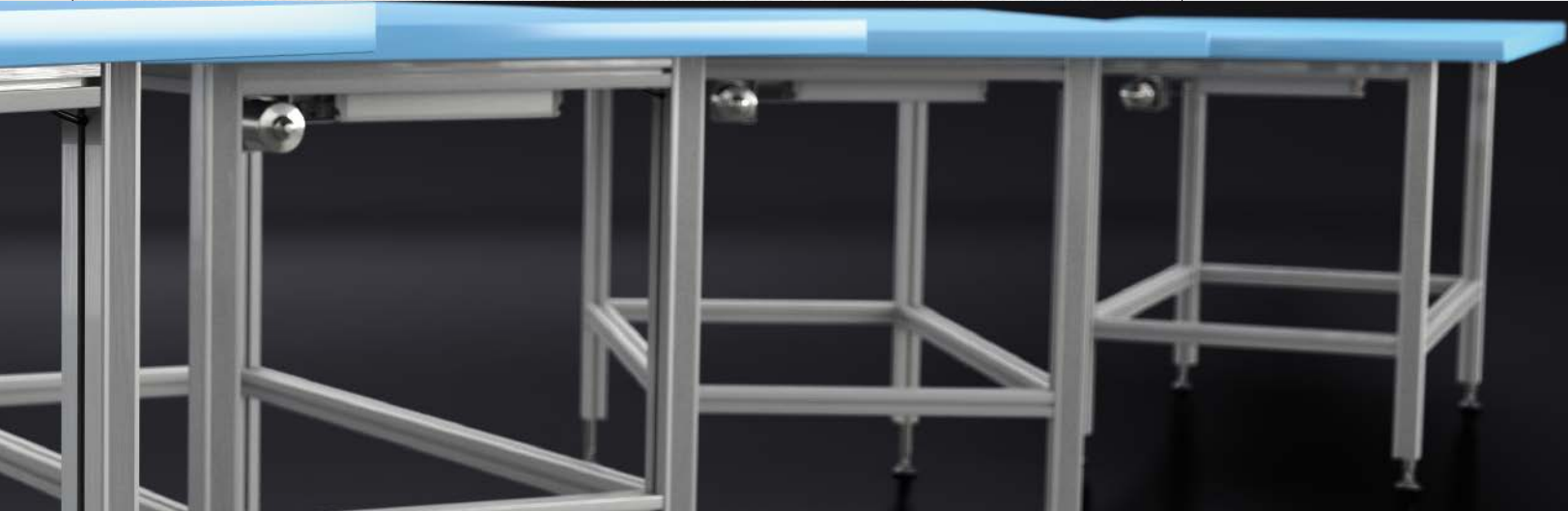

Base frame **TQ-4**

	A
TQ-4 595	23" [595 mm]
TQ-4 995	39" [995 mm]
TQ-4 1195	47" [1195 mm]
TQ-4 1595	63" [1595 mm]

Detailed CAD drawings in various formats can be found at www.ergoswiss.us.



Elegant and robust

The table leg **TU** is ideal for assembly work stations with high load and stability requirements.

Crossbars are fitted on the welded-on mounting plate. The crossbars are supplied with all the necessary screws.

The height is adjusted by means of a hydraulic pump operated by a hand crank or an electric drive unit.

The table leg is also available with hose rupture protection.

The 13ft (4 m) long hydraulic hose is already mounted on the table leg and vented to ensure easy assembly.

The following accessories are available:

- crossbars of various lengths
- adjustable feet made of rubber or aluminium
- locking castors (load 150 lbs or 70 kg)



The table leg **TU** consists of two steel tubes. The galvanized guide tube is supported on bearings. The lifting movement is effected by a hydraulic cylinder.

Dimensions of **TU**

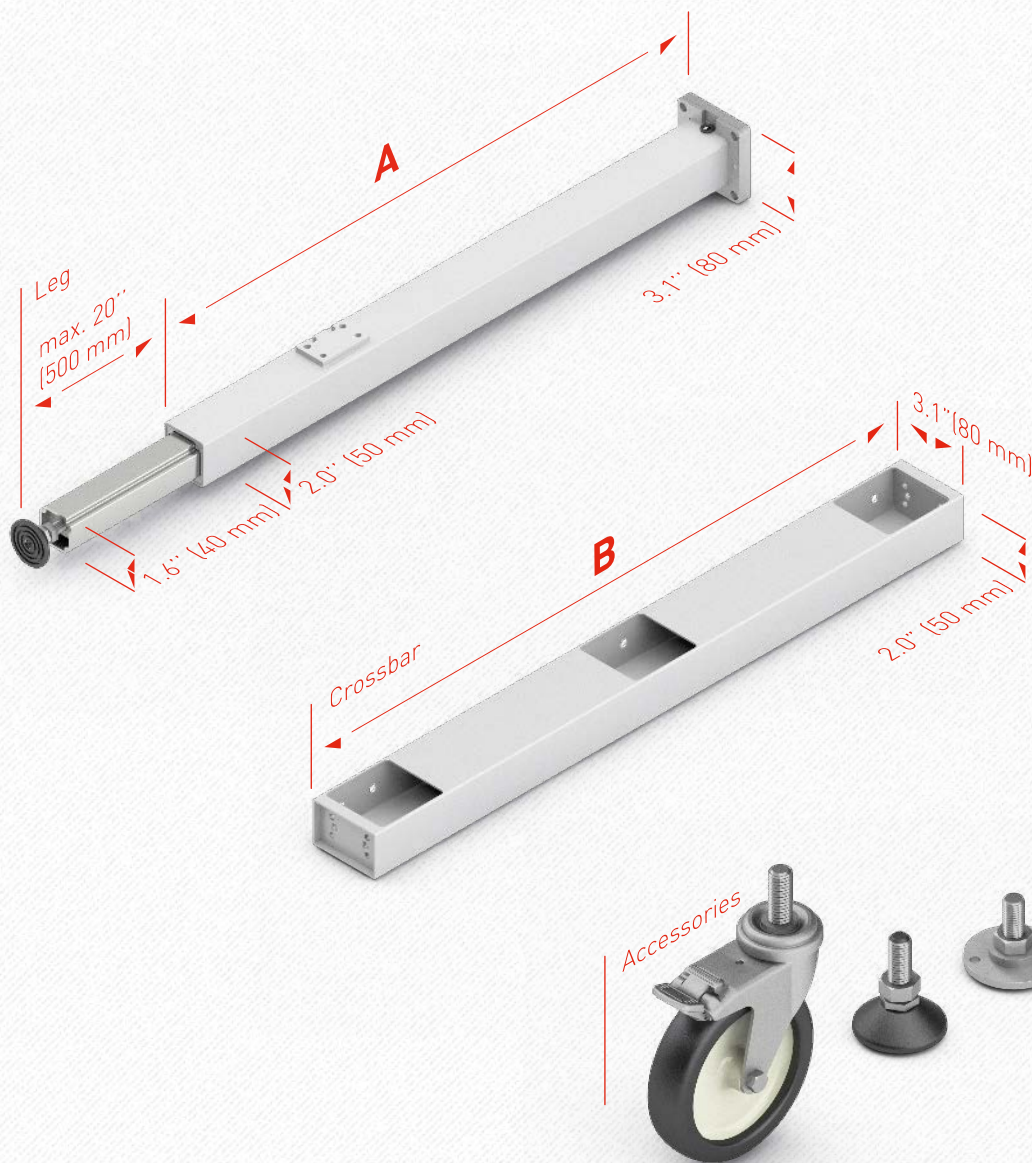

Technical data

- Robust leg with ball track
- Max. load per leg:
330 lbs (150 kg) (**TU 1450**)
550 lbs (250 kg) (**TU 1840**)
- The system load depends on the pump used
- Lifting distance max.
16" or 20" (400 or 500 mm)
- Max. static bending moment
 $M_b = 250 \text{ lbf ft (350 Nm)}$
- Max. dynamic bending moment
 $M_{bdyn} = 110 \text{ lbf ft (150 Nm)}$
- The leg is supplied with a 13ft (4 m) long hydraulic hose prefitted as standard
- Colour : RAL 9006 white aluminium

Table leg **TU**

	A	Lift
TU 1450	28" (710 mm)	20" (500 mm)
TU 1840	28" (717 mm)	16" (400 mm)

Crossbar **TU**

	B
TU 550	22" (550 mm)
TU 750	30" (750 mm)
TU 950	37" (950 mm)
TU 1150	45" (1150 mm)
TU 1550	61" (1550 mm)



The base frame **TU** is very versatile and flexible thanks to its modular construction.

The maximum load is 770 lb, 1320 lbs or 1760 lbs (350 kg, 600 kg or 800 kg) depending on the pump version. The max. height adjustment range is 20" (500 mm).

The **TU-4** base frame consists of 4 legs, a rear crossbar and 2 side crossbars. These are screwed on to the plate welded to the leg. Various screws to mount the table top are included with your order. The base frame is delivered unassembled.

Please note that a pump with hand crank or electric drive unit is also required.

Assembly and operating instructions are included with every delivery.

They can also be downloaded from www.ergoswiss.us.



Dimensions of base frame **TU**

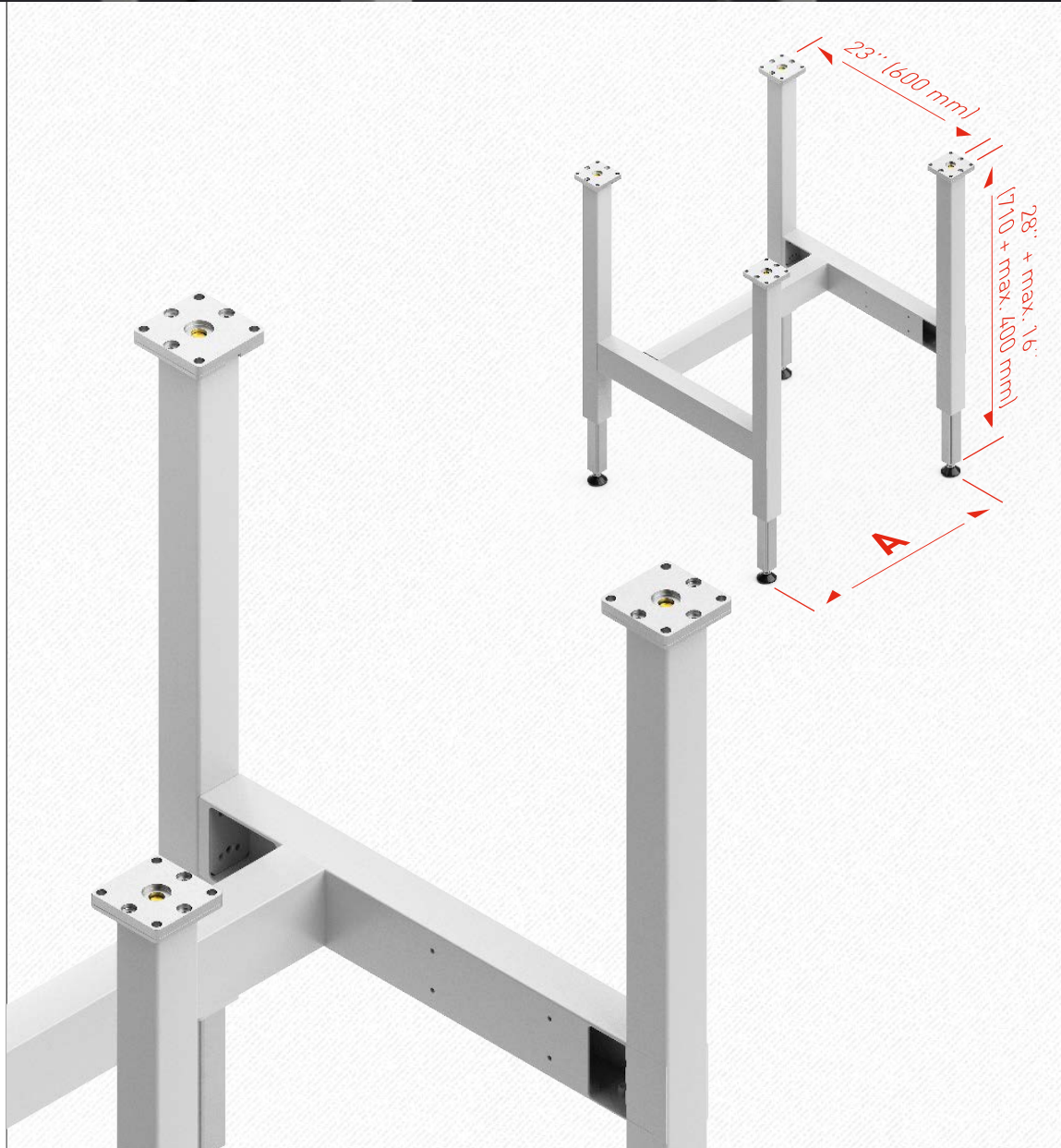

Base frame **TU-4**

	A
TU-4 1000	39" (1000 mm)
TU-4 1200	47" (1200 mm)
TU-4 1600	63" (1600 mm)

Detailed CAD drawings in various formats can be found at www.ergoswiss.us.

System selection Guidelines

These tables will help you to put together your own system on the basis of the required lifting power, the number of cylinders to be activated and the desired lifting distance.

1. System load

What is the maximum load you wish to move? (770 / 1320 / 1760 lbs or 120 / 350 / 600 / 800 kg)

Please note:

- you must not exceed the maximum load per cylinder
- the weight of the table top and any superstructure must be deducted from the system load
- the given loads refer to static loads
- pressure surges can occur if weights are loaded onto the system. In such cases, you should allow a safety factor. Please contact our technician, who will be able to advise you, once you specify the weights, sites of operation, and lowering speed (info@ergoswiss.com)

2. Lifting distance

What lifting distance do you require? (6" to 28", i.e. 150 to 700 mm)

3. Number of cylinders

How many cylinders does your application require? (1 – 10)

4. Cylinder type

What type of cylinder do you need? (Please study the data sheets on the cylinders, linear units and systems.)

5. Pump type

Pump type A (**PA**) can drive 1 or 2 cylinders, pump type F (**PF**) can drive between 3 and 4 cylinders and pump type B (**PB**) can drive between 5 and 10 cylinders.

6. Speed

The selection table shows the lifting speed with a crank or electric drive unit.

7. Drive type

The pump is operated manually using a hand crank or automatically with an electric drive unit. Mains voltage 230 or 110 VAC.

System selection Table

770 lbs (350 kg)	Cylinder type ¹	Pump type for 1 cylinder*	Pump type for 2 cylinders*	Pump type for 3 cylinders	Pump type for 4 cylinders	Pump type for 5 cylinders	Pump type for 6 cylinders	Pump type for 8 cylinders
6" (150 mm) Lift	1415	-	PA 2815	PF 3815	PF 4815	PB 5815	PB 6815	PB 8815
8" (200 mm) Lift	1420	-	PA 2820	PF 3820	PF 4820	PB 5820	PB 6820	PB 8820
12" (300 mm) Lift	1430	-	PA 2830	PF 3830	PF 4830	PB 5830	PB 6830	PB 8830
16" (400 mm) Lift	1440	-	PA 2840	PF 3840	PF 4840	PB 5840	PB 6840	PB 8840
20" (500 mm) Lift	1450	-	PA 2850	PF 3850	PF 4850	PB 5850	PB 6850	PB 8850
24" (600 mm) Lift	1460	-	PA 2860	PF 3860	PF 4860	PB 5860	PB 6860	PB 8860
28" (700 mm) Lift	1470	-	PA 2870	PF 3870	PF 4870	PB 5870	PB 6870	PB 8870
Lift per crank revolution		-	0.2" (5 mm)/rev.	0.2" (5 mm)/rev.	0.2" (5 mm)/rev.	0.2" (5 mm)/rev.	0.2" (5 mm)/rev.	0.2" (5 mm)/rev.
Lifting speed with motor		-	0.6"/s (15 mm/s)	0.6"/s (15 mm/s)	0.6"/s (15 mm/s)	0.6"/s (15 mm/s)	0.6"/s (15 mm/s)	0.6"/s (15 mm/s)
1320 lbs (600 kg)	Cylinder type ¹	Pump type for 1 cylinder*	Pump type for 2 cylinders	Pump type for 3 cylinders	Pump type for 4 cylinders	Pump type for 5 cylinders	Pump type for 6 cylinders	Pump type for 8 cylinders
4" (110 mm) Lift		-	PA 2820	PF 3820	PF 4820	PB 5820	PB 6820	PB 8820
7" (180 mm) Lift	1820	-	PA 2830	PF 3830	PF 4830	PB 5830	PB 6830	PB 8830
9" (240 mm) Lift	1830	-	PA 2840	PF 3840	PF 4840	PB 5840	PB 6840	PB 8840
12" (300 mm) Lift	1830	-	PA 2850	PF 3850	PF 4850	PB 5850	PB 6850	PB 8850
16" (400 mm) Lift	1840	-	PA 2866	PF 3866	PF 4866	PB 5866	PB 6866	PB 8866
Lift per crank revolution		-	0.12" (3 mm)/rev.	0.12" (3 mm)/rev.	0.12" (3 mm)/rev.	0.12" (3 mm)/rev.	0.12" (3 mm)/rev.	0.12" (3 mm)/rev.
Lifting speed with motor		-	0.35"/s (9 mm/s)	0.35"/s (9 mm/s)	0.35"/s (9 mm/s)	0.35"/s (9 mm/s)	0.35"/s (9 mm/s)	0.35"/s (9 mm/s)
1760 Lbs	Cylinder type ¹	Pump type for 1 cylinder*	Pump type for 2 cylinders	Pump type for 3 cylinders	Pump type for 4 cylinders	Pump type for 5 cylinders	Pump type for 6 cylinders	Pump type for 8 cylinders
4" (110 mm) Lift	1815	-	-	-	PF 4418	PB 5418	PB 6418	PB 8418
7" (180 mm) Lift	1820	-	-	-	PF 4430	PB 5430	PB 6430	PB 8430
9" (240 mm) Lift	1830	-	-	-	PF 4440	PB 5440	PB 6440	PB 8440
Lift per crank revolution		-	-	-	0.07" (1.8mm)/rev.	0.07" (1.8mm)/rev.	0.07" (1.8mm)/rev.	0.07" (1.8mm)/rev.
Lifting speed with motor		-	-	-	0.2"/s (5 mm/s)	0.2"/s (5 mm/s)	0.2"/s (5 mm/s)	0.2"/s (5 mm/s)

* The maximum load is 660 lbs (300 kg) when using one cylinder

** The maximum load is 1100 lbs (500 kg) when using 2 cylinders

¹ Cylinder **CB, CD, CE, CG, CH, CI**, linear unit **LA, LB, LD, LH, LG** or system **TA, TT, TQ, TU, TL, TM**

Please note the following maximum lifting distances of the various cylinder types:

System **LH**: 20" (500mm) | System **TT, TQ, TL, TM**: 16" (400mm) | System **TA, TU**: 20" (500 mm)

Our Ergo **Distribution partners**



Australia | Austria | Belgium | Canada | Czech Republic | Finland
France | Germany | Italy | Japan | Luxembourg | Netherlands | Poland
Slovakia | South Korea | Spain | Sweden | Switzerland | USA

Ergo Service

Our aim is to provide you with the best possible support for your projects. To help you achieve your goals, we can offer you the following services:

– **Technical advice | Competent and sound**

Trained and experienced specialists are available around the world to advise you, either on site, over the phone or by e-mail.

– **Configurator and online quotation tool | 24 hours a day, 365 days a year**

You can assemble the right lifting system or base frame for your needs in the online configurator at any time. The corresponding quotation will be sent to your e-mail address within minutes.

– **Always ready to deliver | Anytime, anywhere you want**

All the products in our standard range are available within 3 weeks, even in large quantities. Depending on the size of the delivery, we can deliver straight from our main factory in Switzerland or from our Central European warehouse in the Netherlands.

– **CAD data, instructions | Freely available at any time**

3D data and operating instructions are freely available on our website in several languages, without the need for you to register. Our YouTube channel also offers many useful tutorial videos.

– **Standards, “CE/UL” European conformity, certificates | Comprehensively tested**

You can find the most common test certificates, conformity and installation declarations on our website in the Downloads section. Our engineers place a high priority on designing products that conform to common standards. Our systems are regularly tested for the risks they might pose and are also subject to long-term testing and tested by certified institutes (TÜV - German Technical Inspection Association, Electrosuisse – Swiss Association for Electrical Engineering, Power and Information Technologies).

– **After-sales service | Support 4ever**

If you are not happy with a delivery or a lifting element does not function as it should, simply contact our experienced service team who offers support in such matters.

– **Innovation | Takes us further together**

Talk to us about your ideas and requirements! Your opinions and suggestions are very important for our product development. This is the only way we can remain innovative and satisfy your needs as a customer.

Ergo Service



Additional products such as spindle lifting systems can be found in our Spindle Lifting Systems catalogue and on our website at **www.ergoswiss.us**.

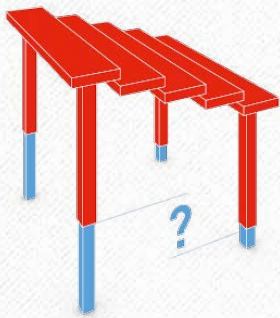

Assemble your very own lifting system at **www.ergoswissconfig.com**. Whether you need individual lifting elements or a complete base frame, a few clicks from you is all we need to configure a suitable product. You will receive your personal quotation immediately by e-mail.



Use our Online Shop available across Europe for easy and convenient ordering of hydraulic and spindle lifting systems, table bases, screen lifts and accessories. Your order will be delivered within two to three days.